

Elecraft Transverter Model XV432

Assembly Manual

Rev C, April 2006

Copyright © 2006, Elecraft; All Rights Reserved



Table of Contents

INTRODUCTION	1
Customer Service and Support	1
Repair Service	1
PREPARING FOR ASSEMBLY	2
Overview of the Kit	2
Tools Required	2
Preventing Electrostatic Discharge Damage	3
Unpacking and Inventory	3
Identifying Parts	3
Assembly Process	5
Forming Component Leads	5
Step-By-Step Procedures	5
Soldering, Desoldering and Plated-Through Holes	6
PARTS INVENTORY	7
BOARD ASSEMBLY PROCEDURE	17
Front Panel PCB	17
RF PCB Assembly	22
Final Assembly	40
TEST AND ALIGNMENT	43

Introduction

This is the assembly manual for the Elecraft XV432 transverter kit. A separate manual covers the assembly of the Elecraft XV50, XV144 and XV222 transverters.

Full details of the Elecraft transverters including specifications, installation, operation, circuit descriptions, options, troubleshooting and maintenance instructions are included in the Owner's Manual which accompanies this kit.

This is an intermediate-to-advanced kit, yet you'll be surprised at how uncomplicated it is to build. All of the radio frequency (RF) circuits are on one printed circuit board (PCB). A second smaller PCB holds the microcontroller and front-panel LEDs. High-quality, double-sided PCBs are used, with plated-through holes for optimal RF performance. Point-to-point wiring is minimal. All components to be installed have wire leads; the few surface-mount devices required are pre-installed on the PCB.

Customer Service and Support

Whether you build the kit or buy a factory-built transverter, you'll find a wealth of information on our web site at www.elecraft.com. Among the materials there you'll find the latest application notes, photographs, any updates to this manual, and information on new products. We also have a popular e-mail forum, for which you can sign up from the web site. It's a great way to interact with other Elecraft owners, exchange ideas and find answers to many questions.

You can also get assistance by telephone or by sending an e-mail to support@elecraft.com. E-mail is preferable because it gives us a written record of your question. Telephone assistance is available from 9 A.M. to 5 P.M. Pacific time, Monday through Friday (except US Holidays) at 831-662-8345.

Repair Service

Contact Elecraft before returning your equipment to obtain the current information on repair fees and the address where you should ship your unit.

To ship the unit, first seal it in a plastic bag to protect the finish. Use a sturdy packing carton with at least 3-in (8 cm) of foam or shredded paper on all sides. Seal the package with reinforced tape. (Neither Elecraft or the carrier will accept liability for damage due to improper packaging.)

Elecraft 1-Year Limited Warranty

If building a kit, complete the assembly, carefully following all instructions in the manual, before requesting warranty service.

What is covered: During the first year after the date of first consumer purchase, Elecraft will replace defective parts free of charge (post-paid). We will also correct any malfunction caused by defective parts and materials. You must send the unit at your expense to Elecraft. We will pay return shipping.

What is not covered: This warranty does not cover correction of assembly errors or misalignment; repair of damage caused by misuse, negligence or builder modifications; or any performance malfunctions involving non-Elecraft accessory equipment. **The use of acid-core solder or any corrosive or conductive flux or solvent will void this warranty in its entirety.** Also not covered is any reimbursement for loss of use, inconvenience, customer assembly or alignment time, or cost of unauthorized service.

Limitation of incidental or consequential damages: This warranty does not extend to non-Elecraft equipment or components used in conjunction with our products. Any such repair or replacement is the responsibility of the customer. Elecraft will not be liable for any special, indirect, incidental or consequential damages, including but not limited to any loss of businesses or profits.

Preparing for Assembly

Overview of the Kit

The Elecraft XV transverters use modular construction, both physically and electrically. This concept extends to the chassis. Any chassis element can be removed to provide access for troubleshooting.

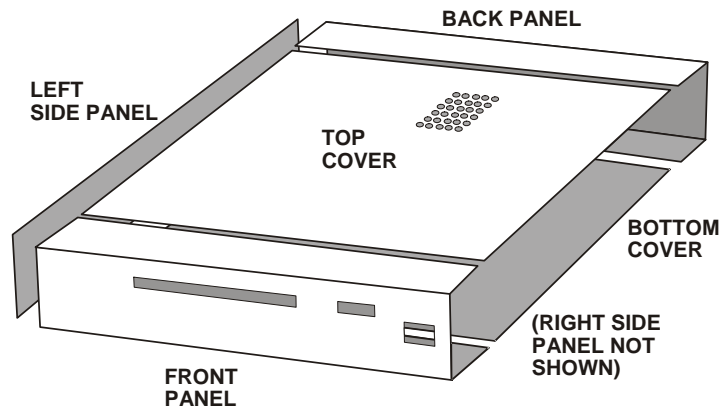

Figure 1. XV Transverter Modular Cabinet Parts.

There are two printed circuit boards (PCBs) in the transverter: the front panel PCB, which sits vertically behind the front panel, and the large RF PCB.

The PCBs are interconnected using board-to-board connectors which eliminates the need for a wiring harness. Gold-plated contacts are used on these connectors for reliability.

Tools Required

You will need the following tools to build this kit:

- Fine-tip temperature-controlled soldering station with 700 or 800°F tip (370-430°C). Do not use a high-wattage iron or gun with small components since this can damage pads, traces, or the parts themselves.
- IC-grade, small-diameter (.031”) solder (Kester #44 or equivalent).
- Desoldering tools and supplies are invaluable if you make any modifications or need to do any repairs. Narrow solder wick or a good vacuum desoldering tool such as the Soldapullt® model DS017LS are recommended. See *Soldering, Desoldering and Plated-Through Holes*, on page 6 for more information.



DO NOT use acid-core solder, water-soluble flux solder, additional flux or solvents of any kind. Use of any of these will void your warranty.

- Screwdrivers: a small, #2 Phillips and a small flat-blade for slotted screws.
- Needle-nose pliers.
- Small-point diagonal cutters, preferably flush cutting.
- Digital Multimeter (DMM) for voltage checks and confirming resistor values. A DMM with capacitance measurement capability is desirable, but not required.
- Noise generator (Elecraft N-Gen or equivalent¹) or signal generator with output in the RF frequency range of the transverter.
- RF power meter capable of measuring RF power levels up to 25 watts at the RF frequency used by the transverter.
- 50-ohm dummy load capable of handling 25 watts, minimum, suitable for 500 MHz.

Refer to www.elecraft.com for tool sources and solder recommendations.

¹ Check www.elecraft.com for availability.

Preventing Electrostatic Discharge Damage

Your XV transverter uses integrated circuits and transistors that can be damaged by electrostatic discharge (ESD). Problems caused by ESD can be difficult to troubleshoot because components may be degraded but still operating, rather than fail completely.

To avoid such problems, simply touch an unpainted, grounded metal surface before handling any such components and occasionally as you build, especially after moving about.

For maximum protection, we recommend you take the following anti-static precautions (listed in order of importance):

1. Leave ESD-sensitive parts in their antistatic packaging until you install them. The packaging may be a special bag, other container or the leads may be inserted in conductive foam (Figure 2). Parts which are especially ESD-sensitive are identified in the parts list.
2. Touch an unpainted metal ground before handling any sensitive parts or wear a conductive wrist strap with a series 1 megohm resistor. **DO NOT attach yourself directly to a ground as this poses a serious shock hazard.**
3. Make sure your soldering iron has a grounded tip.
4. Use an antistatic mat on your work bench.



Figure 2. A common antistatic packaging is conductive foam which keeps all of the terminals of a device at the same potential.

Unpacking and Inventory

We strongly recommend that you do an inventory of the parts before beginning to assemble the kit. Even if you don't count all the parts, an inventory is helpful to familiarize yourself with them. A complete parts list is included in the next section.

Identifying Parts

The parts list contains illustrations of the parts to help you identify them. Identifying marks on the individual parts are shown in the text in parenthesis. For example, "Transistor Q4 (PN2222)..." indicates a transistor, Q4, which may be located in the parts list that has the characters shown in parenthesis printed on it. Sometimes these letters are not obvious. For example, they may be printed in light gray on a black body. Also, there may be other marks on the device in addition to the letters listed.

Identifying Resistors

Resistors are identified by their power capacity and their resistance value. The power rating in watts determines the physical size of a resistor. The most common resistors are 1/4 watt. Higher wattage resistors are proportionately larger. The resistance value and wattage of each resistor is shown in the Parts Lists and in the individual steps of the assembly procedures. The silk-screened outlines on the PCBs indicate the relative physical size of the resistors as well.

Most resistors use a color code. The color bands are listed in the text along with the values of each resistor. For example, "R4, 100k (brn-blk-yl)..." indicates a 100k ohm resistor and the colors to look for are brown, black and yellow, starting with the band nearest the end of the resistor.

Some resistors use numbers instead of color bands. For example, an 820 ohm resistor might be stamped with the digits 821 instead of having gray, red and brown color bands. Some larger resistors have their value in ohms stamped on the body using numbers. For, example the 820 ohm resistor would be stamped with 820 instead of 821 as described above. Normally, when the value is shown in ohms it will be followed with the word "ohms" or the Greek letter omega: Ω

Reading Resistor Color Codes

It is very helpful if you learn to read the color codes. A color code chart showing how to read the four color bands on resistors with a 5% or 10% tolerance is shown in Figure 3. 1% resistors are similar except that they use a fifth band to provide a way of showing another significant digit. For example, a 1,500 ohm (1.5 k-ohm) 5% resistor has the color bands brown, green and red signifying one, five and two zeros. A 1,500 ohm (1.5 k-ohm) 1% tolerance resistor has the color bands brown, green, black and brown signifying one, five, zero, and one zero.

The optional band shown in Figure 3 indicates other performance specifications for the resistor. When used, it is separated from the other color bands by a wider space.



If in doubt of a resistor's value, use a DMM. It may be difficult to see the colors on some resistors, particularly 1% tolerance resistors with a dark blue body. Do NOT be concerned with minor deviations of your DMM reading from the expected value. Typical errors in most DMMs and the tolerances of the resistors normally produce readings that are slightly different from the value indicated by the color bands.

Identifying Molded Inductors

Small molded inductors have color bands that use the same numeric values as resistors but they start near the center of the inductor and work toward the end. These colors are listed in the text after the value of the inductor, for example: 27 μ H (red-vio-blk). The red stripe would be near the center of the inductor and the black stripe would be closer to the end. On very small chokes, the first color will be only slightly farther from one end than the last color. There may be a variety of other stripes on inductors as well, indicating their tolerance, conformance to certain specifications and other data.

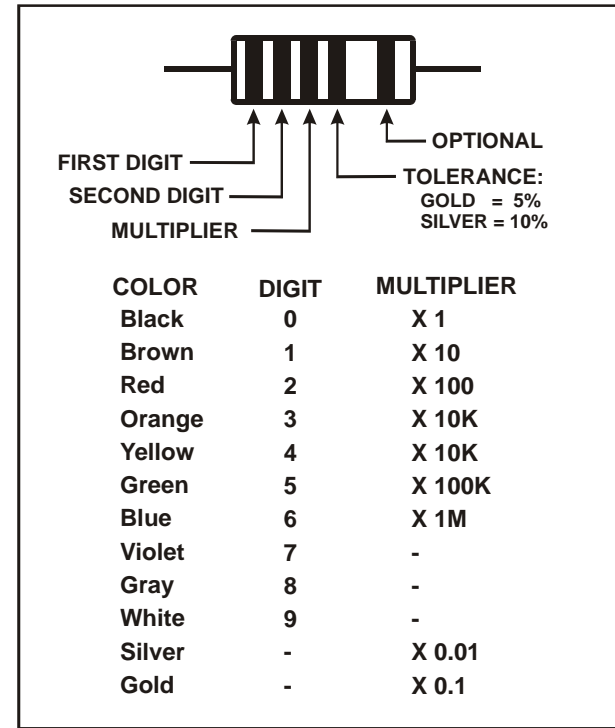

Figure 3. Resistor Color Code.

Identifying Capacitors

Capacitors are identified by their value and the spacing of their leads.

Small-value fixed capacitors usually are marked with one, two or three digits and no decimal point. The significant digits are shown in parenthesis in the text. For example: "C2, .01 (103)".

If one or two digits are used, that is always the value in picofarads (pF). If there are three digits, the third digit is the multiplier. For example, a capacitor marked “151” would be 150 pF (15 multiplied by 10^1). Similarly, “330” is 33 pF and “102” is 1000 pF (or .001 μ F). You may think of the multiplier value as the number of zeros you need to add on to the end of the value.

Note: In rare cases, a capacitor manufacturer may use “0” as a decimal placeholder. For example, “820” might mean 820 pF rather than 82 pF. Such exceptions are usually covered in the parts lists. If possible, measure the values of all capacitors below .001 μ F. Most DMMs include capacitance measurement capability.

Fixed capacitors with values of 1000 pF or higher generally use a decimal point in the value, such as .001 or .002. This is the value in microfarads (μ F). Capacitors also may have a suffix after the value, such as “.001J”.

The lead spacing is noted in the Parts Lists for most capacitors. If two different types of capacitors have the same value, the lead spacing will indicate which one to use. When the lead spacing is important, both the value and the lead spacing is shown in the assembly procedure. For example, “LS 0.1” means that the Lead Spacing is 0.1 in.

Hard-to-Identify Capacitor Values

2.2 pF: These are “disc ceramic” capacitors with round, pillow-shaped bodies about 1/8” (3 mm) in diameter and a black mark on the top. The capacitor should be labeled “2.2” but the marking sometimes requires a magnifying glass to see clearly.

150 pF: These capacitors are marked “151” on one side, but the other side may be marked #21ASD. The “#21” may look like “821”.

Assembly Process

There are four steps in the transverter assembly process:

1. Front panel PCB assembly.
2. RF PCB assembly.
3. Final assembly.
4. Test and alignment.

Follow the assembly process in the order given. Each part builds on what has been completed before it. For example, the front panel PCB assembly procedure contains details about installing certain parts that are not repeated when similar parts are installed later.

Forming Component Leads

Sometimes the space provided for a component on the PCB is larger than the distance between the leads on the part itself. In such cases, you’ll need to carefully bend the leads out and then down to fit the given space. Always use long-nose pliers to accomplish this task, and *bend* the leads – don’t tug on them. This is especially important with capacitor leads, which are fragile.

Step-By-Step Procedures

Perform the assembly steps in each procedure in the order given, and do not skip any steps. Otherwise you may find that you’ve installed one component that hinders the installation of another. When groups of components are installed, they are listed in a logical order as you work around the PCB to reduce the time needed to find where each part goes.



Each step in the assembly procedures has a check box.

Some steps have more than one task. For example, you may be installing a number of components listed. When a step has a number of tasks, each task is indented with space for a check mark:



Check off each task as you complete it.

Soldering, Desoldering and Plated-Through Holes

CAUTION: Solder contains lead, and its residue can be toxic. Always wash your hands after handling solder.

The printed circuit boards have circuitry on both sides (“double sided”). Boards of this type require *plated-through holes* to complete the electrical connections between the two sides.

When you solder components on these PCBs the solder fills the plated holes making excellent contact. This means that you do not need to leave a large “fillet” or buildup of solder on top of the pads themselves. *A small amount of solder will do for all connections.*

Unfortunately, removing components from double-sided PCBs can be difficult. To remove a multi-pin component you’ll need to get all of the solder out of every hole to free the leads. You will need to use solder wick or a vacuum desoldering tool (see *Techniques* below).

The best strategy for avoiding desoldering is to place all components properly the first time. Double check values, component placement and orientation. Take care to avoid ESD damage to components.

Techniques to Avoid Damaging the PCB when Desoldering











- Don’t pull a lead or pin out of a hole unless the solder has been removed completely, or you are applying sufficient heat melt the solder. Otherwise you can pull the entire plating out of the hole.
- Limit soldering iron contact to a few seconds at a time.
- Use small size solder wick, about 0.1” (2.5 mm) wide. Use wick on both the top and bottom solder pads when possible. This helps get all of the solder out of the hole.
- Buy and learn to use a large hand operated vacuum desoldering tool such as the Soldapull® model DS017LS. Small solder suckers are not effective.
- When removing ICs and connectors, clip all of the pins at the body first, then remove each pin *one at a time*, working slowly. You may damage pads and traces by trying to remove a component intact, possibly leaving a PCB very difficult to repair.
- Invest in a PCB vise with a heavy base if possible. This makes removing parts easier because it frees up both hands.
- If in doubt about a particular repair, ask for advice from Elecraft or someone with PCB repair experience. Our e-mail reflector is an excellent source of help.

















Parts Inventory





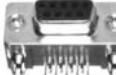







You should do a complete inventory. Contact Elecraft if you find anything missing.

 Leave painted panels wrapped until they are needed during assembly. This will protect the finish.













Cabinet and RF PCB components

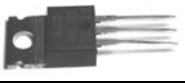



Picture	Ref. Designator(s)	QTY	Description	Part #
		1	RF Printed Circuit Board, XV432  Handle with care – ESD Sensitive. This PCB is supplied with a number of surface-mount devices (SMD) pre-mounted. Some of these components are static sensitive and vulnerable until other parts are installed on the PCB. There are temporary jumpers across the solder pads for L1 and R13 to prevent static damage to Q3. Do not remove these jumpers until instructed to do so. Take ESD precautions (see page 3) when handling.	E850218
		1	Front Panel	E100153
		1	Rear Panel	E100154
		1	Front Panel Label, XV432	E980062
See Figure 1		2	Side Panel	E100140
		1	Top Cover	E100267
		1	Bottom Cover	E100268
		1	Heat Spreader	E100156
		8	2-D Fastener	E100078
		2	Right Angle Bracket	E700073
		40	Pan Head Black Machine Screw, 3/16 inch, 4-40.	E700015
		5	Pan Head Zinc or Stainless Machine Screw, 5/16 inch, 4-40	E700077
		2	Pan Head Black Machine Screw, 1/2 inch, 4-40	E700030
		4	Pan Head Black Machine Screw, 5/8 inch, 4-40	E700114





Picture	Ref. Designator(s)	QTY	Description	Part #
		14	Machine Screw Nut, 4--40	E700011
		14	Split Lock washer, #4 (Includes two spares)	E700004
		12	Internal Tooth Lock washer, #4	E700010
		2	Flat Washer, #4	E700044
		2	Ground Lug	E700062
		2	M-F Standoff for DB9 Connector	E700078
		4	Rubber Foot, Self Adhesive  A Bail kit is available as an optional accessory if desired. The Bail will hold the front of the transverter up at a convenient viewing angle. See www.elecraft.com for details	E980067
	J1	1	Type "N" Chassis Mount Female Connector	E620069
	J4, J5	2	RCA Jack	E620057
		1	Connector, RCA, Male (Mates with J4)	E620108
	J2, J3, J8	3	BNC Connector PC Mount	E620020
		3	Nut for BNC Connector	E700059
		3	Lock washer for BNC Connector	E700058
	J6	1	DB9 Female Connector, PC Mount	E620058
		1	DB9 Male Cable Connector (Mates with J6)	E620049
		1	DB9 Back Shell (Shell components are normally packaged together in a transparent bag).	E620050
		4	Anderson Powerpole® Connector Crimp Terminal	E620062









Picture	Ref. Designator(s)	QTY	Description	Part #
		1	Anderson Powerpole® Connector Roll Pin	E700071
	J7 & mating cable plug	2	Anderson Powerpole® Shell, Red	E620059
	J7 & mating cable plug	2	Anderson Powerpole® Shell, Black	E620060
	P1	1	Header Connector, 12 Pin , Right Angle	E620065
	JP9 ² ,JP7, JP8	3	Header Connector, 2 Pin	E620054
	JP1,JP2,JP3,JP4, JP5, JP6, JP9 ²	7	Header Connector, 3 Pin	E620007
		9	Header Shorting Block, 2 Pin	E620055
	S2	1	DPDT Power switch	E640006
	SW1	1	4 Pole DIP switch	E640014
		1	Key Cap, Black	E980023
	K1, K2, K4, K5, K6, K7, K8, K9	8	Relay (G6E-134P)	E640011
	K10	1	Relay (G6B-1174P)	E640028
	K3	1	Relay, SPDT, 12 A, 12 VDC, Large (KLT1C12DC12).	E640012
	Y1	1	Crystal, 134.667 MHz 5th Overtone	E660030

² JP9 comprises a three pin and a two pin header connector.



Picture	Ref. Designator(s)	QTY	Description	Part #
	F1	1	Resettable Fuse, 8 Ampere, 16 Volt	E980113
	U2	1	Voltage Regulator, 9 Volt, LM78L09	E600054
	Q6	1	Transistor, NPN, PN2222A	E580001
	U4	1	Voltage Regulator, 5 Volt, LM7805 or LM78M05	E600024
	Q5	1	Transistor, MOSFET, 2N7000  ESD Sensitive. Leave the leads inserted in the conductive foam pad until ready to install. Take ESD precautions (see page 3) when handling.	E580002
	Q4	1	Transistor, HEXFET, IRL620	E580018
	U3	1	Voltage Regulator, 5 Volt, LM78L05	E600029
	Q1	1	Transistor, NPN, MPS918	E580022
	U7	1	RF Power Module, TOSHIBA SAU83L  ESD Sensitive. Take ESD precautions (see page 3) when handling.	E600120
Pre-mounted on the PCB	Z1	1	Frequency Mixer, ADEX-10H	E600050
	U1	1	MMIC Amplifier, MAV11	E600122
	U5	1	MMIC Amplifier, MAR-3	E600073
	Q3	1	Transistor, PHEMT, ATF 34143	E580020
	U6	1	SGA7489, Sirenza Gain Block Amplifier (Three lead device with tab. Two leads and tab are soldered to the PCB. Center lead is not connected)	E600055
	U9	1	MMIC, SGA4586	E600121
	D1, D4, D13, D6, D12, D9, D14, D15, D16, D17	10	Diode, 1N4148	E560002
	D7, D8, D2, D18	4	Diode, 1N5711	E560004
	D3	1	Diode, Zener, 6.8 Volt, 1N5235B	E560011
	D5	1	Diode, 1N4007	E560001
	D10, D11	2	Rectangular LED, Red	E570007

Picture	Ref. Designator(s)	QTY	Description	Part #
	R21	1	Resistor, metal oxide, 1 watt, 5%, 820 ohm (821)	E500094
	R20, R26, R27	3	Resistor, metal oxide, 3 watt, 5%, 160 ohm (160)	E500095
	R25, R29	2	Resistor, 1/4 watt, 5%, 56 ohm (grn-blu-blk)	E500096
	R1, R33	2	Resistor, 1/4 watt, 5%, 10K ohm (brn-blk-org)	E500015
	R11, R28	2	Resistor, 1/4 watt, 5%, 1K ohm (brn-blk-red)	E500013
	R18	1	Resistor, 1/4 watt, 5%, 620 ohm (blu-red-brn)	E500097
	R4, R5	2	Resistor, 1/4 watt, 5%, 5.6K ohm (grn-blu-red)	E500007
	R23, R34, R41	3	Resistor, 1/4 watt, 5%, 100K ohm (brn-blk-yel)	E500006
	R40	1	Resistor, 1/4 watt, 5%, 22k ohm (red-red-org)	E500090
	R31	1	Resistor, Metal Film, 1/4 watt, 1%, 15.0K ohm (brn-grn-blk-red)	E500112
	R32	1	Resistor, Metal Film, 1/4 watt, 1%, 3.92K ohm (org-wht-red-brn)	E500110
	R30	1	Resistor, Metal Film, 1/4 watt, 1%, 7.50K ohm (vio-grn-blk-brn)	E500111
	R35	1	Resistor, Metal Film, 1/4 watt, 1%, 5.11K ohm (grn-brn-brn-brn)	E500109
	R16	1	Resistor, 1 watt, 5%, 120 ohm (brn-red-brn)	E500105
	R8, R12, R19	3	Resistor, 1 watt, 5%, 180 ohm (brn-gry-brn)	E500113
	R6	1	Resistor, 1/4 watt, 5%, 240 ohm (red-yel-brn)	E500179
	R24	1	Resistor, 2 watt, 5%, 68 ohm (68)	E500078
	R42	1	Resistor, 1/4 watt, 5%, 4.7 ohm (yel-vio-gld)	E500062
	R10	1	Trimmer Potentiometer, PC mount, 100K ohm (104)	E520001
	R13	1	Trimmer Potentiometer, PC mount, 25 ohm (no resistance value marked).	E520016
	R39	1	Trimmer Potentiometer, PC mount, 1K ohm (102)	E520010
	R22	1	Trimmer Potentiometer, PC mount, 100 ohm (101)	E520008
Pre-mounted on the PCB	R15	1	Resistor 56 ohm SMD, 1206 size	E500099
	R17	1	Resistor, .02 ohm SMD, 2512 size	E500100
	R36	1	Resistor 15 ohm, 1/4 watt 5% SMD	E500181









Picture	Ref. Designator(s)	QTY	Description	Part #
	C1	1	Ceramic Trimmer Capacitor, 2 - 6 pF	E530213
	C26, C60	2	Electrolytic Capacitor, 22 μ F, 25 V	E530012
 <p>Capacitors shown are typical. Different styles may be supplied.</p>	C57	1	Capacitor, 100 pF (101)	E530117
	C12	1	Ceramic Capacitor, 18 pF (18) or (180), LS 0.1,	E530212
	C35	1	Capacitor, 10 pF (100)	E530118
	C55,C56	2	Capacitor, 180 pF (181)	E530075
	C52,C54	2	Capacitor , 150 pF (151)	E530049
	C53	1	Capacitor, 22 pF (220) or (22), LS 0.2	E530027
	C39	1	Capacitor, .001 μ F (102)	E530129
	C65	1	Capacitor, 0.22 μ F (224)	E530079
	C19, C9, C10, C34, C38, C37, C36, C64, C67, C71	10	Capacitor, .01 μ F (103), LS 0.1	E530130
	C29, C68	2	Capacitor, .047 μ F (473), LS 0.1	E530131
	C14, C14A	2	Ceramic Capacitor, 15 pF (15) LS 0.1	E530140
	C18	1	Disc Ceramic Capacitor 4.7pF (4.7), LS 0.2	E530048
Pre-mounted on the PCB	C4, C21, C25, C24, C41, C3, C22, C63, C6, C61, C23, C62, C40, C8, C16, C30, C20, C13, C84, C85, C86	21	Ceramic Capacitor, SMD, .047 μ F, 50 V	E530120
	C66, C31	2	Ceramic Capacitor, SMD, .047 μ F, 50 V	E530214
	C70	1	Ceramic Capacitor, SMD, NPO, 27 pF, 5%	E530121
	C2,C17,C7,C48,C59, C27	6	Ceramic Capacitor, SMD 50V 100pF	E530215
	C44	1	Ceramic Capacitor, SMD, NPA, 50 V 3.3 pF	E530217
	C58, C80, C82, C5	4	Ceramic Capacitor, SMD, NPO, 50 V, 1 pF	E530128
	C33	1	Ceramic Capacitor, SMD, NPO, 50 V, 1.5 pF	E530216
	C42, C43	2	Ceramic Capacitor, SMD 6.8 pF	E530219
	C81	1	Ceramic Capacitor, SMD 5.6 pF	E530220



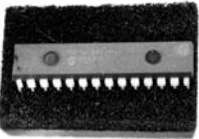

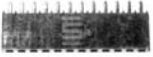
Picture	Ref. Designator(s)	QTY	Description	Part #
	FL1, FL2	2	Helical Filter, Three Section  Do not change the adjustments on these filters until instructed to do so.	E690062
	L15,L16,L17	3	Inductor, .243-.297 μH, Shielded, Gray Plastic Insert.	E690025
	L3, L5	2	Inductor, Shielded, .038-.040 μH, Brown Plastic Insert	E690031
	L4	1	Inductor, . 0.085 - 0.100 μH, Orange with 4-turn Coil	E690023
	L19	1	Inductor, .064 - .080 μH, Red with 2-1/2 Turn Coil	E690029
	L9	1	Inductor, Molded, .47 μH (yel-vio-silver)*	E690020
	L8	1	Inductor, Molded, 15 μH (brn-grn-blk)*	E690012
	L2, L22, Z3	3	Inductor, Molded, .1 μH (brn-blk-silver)*	E690021
	L7	2	Ferrite Bead	E980029
	L10	12 in. (30 cm)	Solid Insulated Wire, #24	E760008
	L1	4 in. (10 cm)	Bare Copper wire, #14	E760023

* The color codes on these inductors are different than those used on resistors. See *Identifying Molded Inductors* on page 4.

Picture	Ref. Designator(s)	QTY	Description	Part #
	FAN 1	1	Fan	E980114
		1	5" Hex Tuning Tool	E980068
		1	Thermal Insulator, large	E980079
		1	Thermal Insulator, small	E980078
		1 in (2.54 cm)	Teflon Tubing	E980075
		4 in. (10 cm)	Copper Wire, #16, Bare, Tinned	E760031
		5 ft. (1.5 m)	Red/Black 2-Conductor Wire, #12 Stranded (for DC power wiring)	E760017
		3 ft. (91 cm)	4-Conductor Shielded Cable (serial I/O cable)	E760009

Front panel PCB components.

Picture	Ref. Designator(s)	QTY	Description	Part #
		1	Printed Circuit Board	E100168
		2	Screw, Fillister Head, 1/8 inch, 2-56	E700023
	U1	1	Microcontroller PIC16F872, Programmed (packaged in foam)  Handle with care – ESD Sensitive. Do not remove it from its conductive foam until you are instructed to install it.	E610014
		1	IC Socket, 28 pin (packaged in foam)	E620011
	J1	1	Header Socket, 12 Pin	E620008
	D1, D2	2	Rectangular LED, Red	E570007
	D3	1	Rectangular LED, Yellow	E570009
	D4, D5, D6, D7, D8, D9, D10,	7	Rectangular LED, Green	E570008
	R6, R7, R8, R9, R10, R11, R12, R13, R14, R15, R16, R21, R22, R23	14	Resistor, Metal Film, 1/4 watt 120 ohm (brn-red-brn)	E500022
	R1	1	Resistor, Metal Film 1/4 watt, 5%, 220 ohm (red-red-brn)	E500002
	R2	1	Resistor, Metal Film 1/4 watt, 5%, 470 ohm (yel-vio-brn)	E500003
	R3	1	Resistor, Metal Film 1/4 watt, 5%, 10K ohm (brn-blk-orn)	E500015
	R4, R17	2	Resistor, Metal Film 1/4 watt, 5%, 100K ohm (brn-blk-yel)	E500006
	R25	1	Resistor, Metal Film 1/4 watt, 5%, 270K ohm (red-vio-yel)	E500101
	R18, R19, R20, R24	4	Resistor, Metal Film 1/4 watt, 5%, 2.2K ohm (red-red-red)	E500104
	R5	1	Resistor, Metal Film 1/4 watt, 5%, 1 megohm (brn-blk-grn)	E500024
	C4	1	Capacitor, Monolithic, .001 μ F, (102), LS 0.1	E530129
	C2, C3	2	Capacitor, Monolithic, .01 μ F, (103), LS 0.1	E530130
	C1	1	Capacitor, Monolithic, .047 μ F (473), LS 0.1	E530131

Picture	Ref. Designator(s)	QTY	Description	Part #
	D11	1	LED Light Bar, Yellow (packaged in foam)	E570011
	Q1,Q2,Q3,Q4,Q5,Q6, Q7	7	Transistor, NPN, PN2222	E580001
	Z1	1	Ceramic Resonator, 4 MHz	E660001
	JP1	1	Header Connector, 2 pin	E620054
		1	Header Shorting block, 2 pin	E620055

Board Assembly Procedure

Follow the assembly procedures in the order given. The steps have been organized in a sequence that allows best access to place each part.

Front Panel PCB

Place the front panel PCB on top of the heat spreader with the silk-screened side down as shown in Figure 4. Temporarily attach the PCB to the heat spreader with a single 3/16" (4.8 mm) pan-head screw.

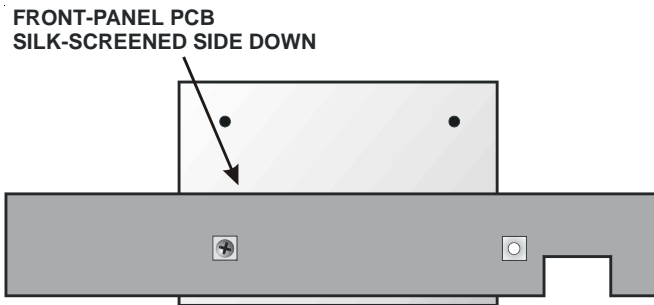

Figure 4. Preparing Front Panel PCB to Install Light Bar.

Prepare the leads of the yellow light bar for mounting on the PCB by bending them as shown in Figure 5. Press the leads against a smooth, hard surface and roll the light bar until they are at about a 45 degree angle to the side of the light bar.

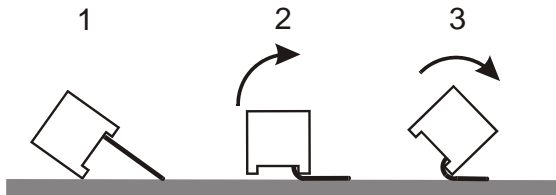

Figure 5. Preparing Light Bar Leads.

Position the light bar in the cutout of the PCB as shown in Figure 6. Adjust the leads as necessary so they line up with the six solder pads at the edge of the cutout. The leads will not pass through the solder pads. The tips of the leads will rest just inside the top of each solder pad.

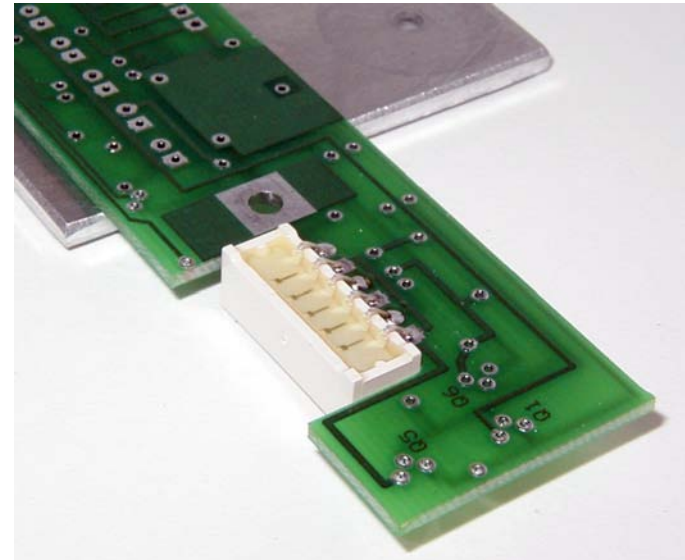

Figure 6. Installing Light Bar.

- Solder the six terminals to the circuit PCB pads.
- Remove the front panel PCB from the heat spreader.



The front panel PCB has parts on *both* sides of the PCB. Follow the instructions carefully. If parts are placed on the wrong side of the PCB, it will not mate with the RF PCB properly or it will not fit inside the enclosure when construction is finished. Parts that go on the back (not silk screened) side of the PCB are identified by asterisks on the silk screening.

Place the 28 pin IC socket in the holes provided at the end of the front panel PCB opposite the light bar you just installed. The socket goes on the BACK of the PCB (the side opposite the silk-screened outline). Orient the socket so the notch in the end is facing away from the end of the PCB, as shown on the outline.

While holding the IC socket against the PCB, wet the tip of your soldering iron with a very small amount of solder and then touch it to a pin and solder pad at one end of the socket to tack-solder it in place.

Tack-solder a second pin at the opposite end of the socket.

Check the IC socket carefully to ensure:

- The socket is on the side of the PCB that is *not* silk-screened.
- The notched end of the socket is on the end farthest from the end of the PCB (as shown on the silk-screened outline).
- The socket is against the PCB at both ends. If necessary, heat the tack-soldered joints and adjust the socket so it is flush.

Solder all 28 pins of the IC socket and trim the leads. Be sure to solder properly the two pins you tack-soldered above.



If your solder joints are not clean and shiny, your iron may not be hot enough, or you may be using the wrong type of solder. These "cold" solder joints will likely result in poor performance, reliability problems, or component failure. You may wish to consult our web site for additional soldering instructions and tool recommendations.

Locate the silk-screened outline for Q5 near the yellow light bar. Install a PN2222 transistor on the *back* side of the PCB (the side that is not silk-screened). The transistor's leads should protrude through the PCB on the silk-screened side.

Note: The wide, flat side of the transistor must line up with the flat side of the silk-screened outline on the PCB (See Figure 7). The part number may be on either side of the transistor.

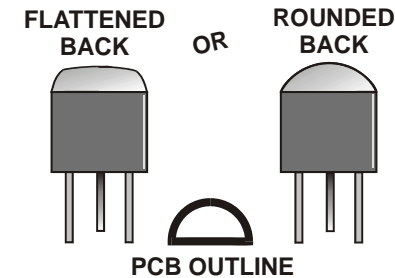

Figure 7. Transistor Orientation Guide.

Position the transistor on the PCB as shown in Figure 8 and bend the leads to hold it in place. Solder and trim the leads as short as possible.

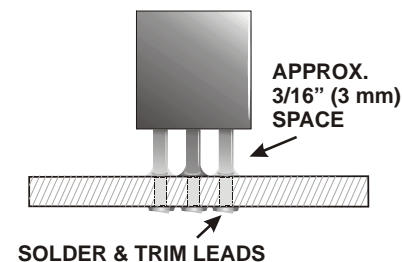

Figure 8. Installing Transistors.



In the steps that follow, you'll be installing groups of components. When working from a long list, install all of the items on one line before moving on to the next. Arrows (\Rightarrow) appear in the list to remind you of this order. Components may be soldered one at a time or in groups. Leads can be trimmed either before or after soldering. After trimming, leads should be 1/16" (1.5 mm) or less in length.

Install six additional PN2222 transistors on the *back* side of the PCB (the side that is *not* silk-screened) just as you did Q5. Align the flat side of each transistor with the outline shown on the silk screening.

__ Q6 \Rightarrow __ Q1 __ Q7
 __ Q2 \Rightarrow __ Q3 __ Q4

Install capacitor C1, .047 μ F (473) on the *back* side of the PCB (the side that is *not* silk-screened). Position the capacitor as shown in Figure 9.

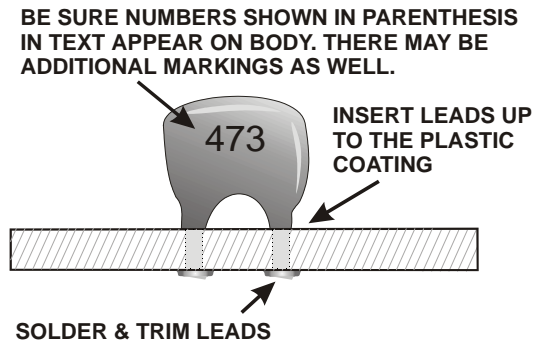

Figure 9. Installing Capacitors.

Install capacitor C4, .001 μ F (102) on the *back* side of the PCB (the side that is *not* silk-screened).

Install ceramic resonator Z1 (4.0 MG or 4.00 MG) on the *back* side of the PCB (the side that is *not* silk-screened). This part may be inserted in either direction. Like the capacitors, insert the resonator as far as the plastic coating on the leads will allow.

Install JP1, a two pin header connector on the *back* side of the PCB (the side that is *not* silk-screened) as shown in Figure 10 . Temporarily place a shorting block on the pins to provide a finger rest while soldering. **Do not hold the solder iron on the pins more than 1 or 2 seconds. Excessive heat will melt the plastic part of the header.**

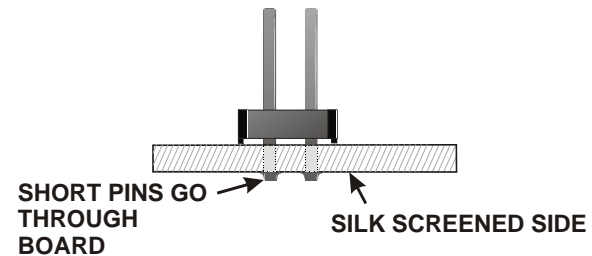

Figure 10. Installing Header Connectors.

- Check to ensure that:
- _ All of the above parts were installed in the *back* of the PCB (the side with *no* silk-screening).
 - _ All parts are soldered.
 - _ All leads are trimmed to 1/16" (1.5 mm) or less.



The remaining parts will be installed on the *front* of the PCB.

Follow the LED installation instructions carefully to preserve the appearance of your transverter's front panel. When finished, the LEDs should be perpendicular to the PCB and in a straight line (See Figure 11).

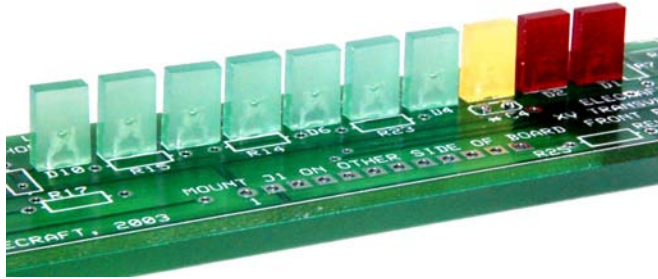

Figure 11. Power LEDs Installed on Front Panel PCB.

- Sort the rectangular LEDs into groups according to color.



Note that one lead of each LED is longer than the other. This is the anode lead. It must be inserted in the right hand solder pad for each LED as shown on the front panel PCB. The right hand pads are square to help identify them. The LEDs will not illuminate if the leads are reversed.

- Insert the leads of a **green** LED through the solder pads provided for D10 on the silk-screened side of the front panel PCB. Be sure the long lead is in the right-hand pad (with the square pad). **Do not solder yet.**

- Hold the LED with the back of the plastic housing flat against the PCB (not tilted). Bend the leads outward on the bottom side to hold it in place.
- Solder one lead of the LED, keeping soldering time to 1 to 2 sec.
- If the LED is tilted or is not flat against the PCB, reheat the lead while pressing the LED down.
- Once the LED is correctly positioned, solder the other lead, again keeping soldering time to 1 or 2 seconds. Then trim both leads.
- Install a **green** LED at D9. **Make sure the long lead is to the right as shown on the PCB.** Before soldering, adjust the LED's position as with D10.
- Install **green** LEDs at D8, D7, D6, D5, and D4. Make sure the long lead is to the **right** for these and all remaining LEDs.
- Install a **yellow** LED at D3.
- Install **red** LEDs at D2 and D1.

Sort all of the resistors by value. If the color bands are difficult to read, use a DMM (digital multimeter) to verify their values. Tape them to a piece of paper with the values labeled.

Install the resistors below on the front (silk-screened) side of the PCB. Align each resistor to rest against the PCB inside the silk-screened outline (See Figure 12). Start with R1 near the light bar end of the PCB.

- __R1, 220 ohm (red-red-brn) ⇒ __R16, 120 ohm (brn-red-brn)
- __R22, 120 ohm (brn-red-brn) ⇒ __R21, 120 ohm (brn-red-brn)
- __R24, 2.2k (red-red-red) ⇒ __R2, 470 ohm (yel-vio-brn)
- __R25, 270k (red-vio-yel) ⇒ __R23, 120 ohm (brn-red-brn)
- __R14, 120 ohm (brn-red-brn) ⇒ __R15, 120 ohm (brn-red-brn)
- __R13, 120 ohm (brn-red-brn) ⇒ __R5, 1 meg (brn-blk-grn)
- __R3, 10k (brn-blk-org) ⇒ __R18, 2.2k (red-red-red)
- __R20, 2.2k (red-red-red) ⇒ __R4, 100k (brn-blk-yel)
- __R17, 100k (brn-blk-yel) ⇒ __R19, 2.2k (red-red-red)
- __R12, 120 ohm (brn-red-brn) ⇒ __R11, 120 ohm (brn-red-brn)
- __R10, 120 ohm (brn-red-brn) ⇒ __R9, 120 ohm (brn-red-brn)
- __R8, 120 ohm (brn-red-brn) ⇒ __R7, 120 ohm (brn-red-brn)
- __R6, 120 ohm (brn-red-brn)

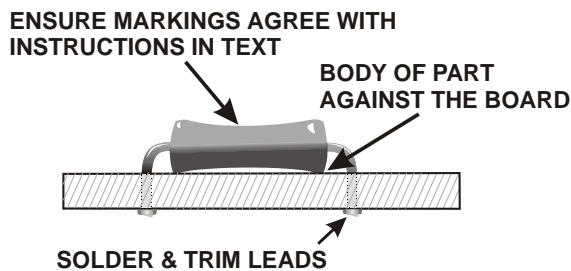

Figure 12. Installing Resistors.

Install the two capacitors listed below on the front (silk-screened) side of the PCB, near the outline of the 28-pin IC socket. **Check each capacitor's labeling carefully for the numbers shown in parentheses.**

__C2, .01 μ F (103)

__C3, .01 μ F (103)

Inspect the PCB carefully for the following:

- _ All connections soldered.
- _ No solder bridges between pads (use a magnifier as needed).
- _ All leads clipped to no more than 1/16" (2 mm) long.

Verify that all component locations on the front panel PCB are filled, except the following:

- _ U1 (controller 16F872) should not be installed in its socket yet.
- _ J1 at the bottom center of the PCB. This will be installed in the next section.

You've finished the front panel PCB assembly procedure. Go to *RF PCB Assembly* on the next page to continue.

RF PCB Assembly

To help you locate the component positions on the large RF PCB, the following steps refer to the five general areas of the PCB shown in Figure 13. Orient the PCB with the component side up as shown.

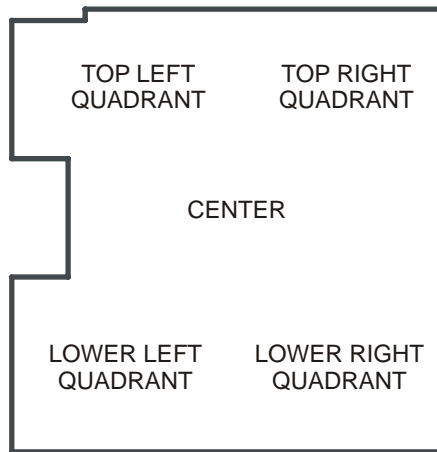

Figure 13. RF PCB Orientation.



Take ESD precautions (see page 3) when handling the RF PCB. Some surface-mounted components are used in the RF circuits for optimal transverter performance. The PCB is supplied with these components pre-mounted. Take care not to damage them.



Do not remove the temporary wire jumpers across the solder pads for L1 and R13 until instructed to do so. The jumpers protect U1 from static damage until the components are installed.

- Locate the two small L brackets. Identify the *shorter* side of the "L", which will be attached to the RF PCB.
- On the RF PCB, locate the hole at either end of the silk-screened lettering: P1 MOUNTS ON OTHER SIDE OF BOARD. These are the holes where the L brackets will be installed.
- Secure the shorter leg of an L bracket loosely to the top (silk screened side) of the RF PCB in each hole using a 4-40 x 3/16" (4.8 mm) black screw. A lock washer is not required at this time.
- Locate the 12-pin female connector (J1) and the 12-pin male connector (P1). Normally J1 is included with the front panel PCB parts and P1 is with the RF PCB parts.
- Slide the 12-pin female connector (J1) onto the pins of the 12-pin male connector (P1). There should be no gap between them.
- Insert P1's right angle pins into the holes on the bottom of the RF PCB near the letters: P1 MOUNTS ON THIS SIDE OF BOARD. **Do not solder yet.**
- Position the front panel PCB as shown in Figure 14. The pins of J1 should be inserted into the holes in the front panel PCB, and the two L brackets should be aligned with their outlines on the back of the front panel PCB. The edge of the RF PCB fits between the socket for U1 and Q2, Q3, Q4 and Z1 on the front panel PCB.

Secure the L brackets loosely to the front panel PCB using two 4-40 x 3/16" (4.8 mm) screws (black). It is not necessary to use lock washers at this time.

Adjust the L bracket positions so the front panel PCB is aligned with the RF PCB. If the gap between the front panel PCB and the RF PCB is wider at one end than the other, you probably have one of the brackets installed backward. Be certain the shorter legs are attached to the RF PCB.

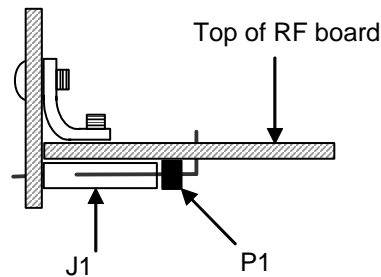



Figure 14. Installing J1 and P1.

- Tighten all four L bracket screws.
- Solder all pins of J1 and P1.
- Remove the two screws holding the front panel PCB to the brackets. Unplug the front panel PCB and set it aside in a safe place.
- Remove the brackets and screws from the RF PCB and set them aside.
- Sort the fixed resistors by wattage and value as follows:
 - Divide the resistors by wattage: 3-watt (physically largest), 2-watt, 1-watt and 1/4 watt (smallest).
 - Among the 1/4 watt resistors, separate the four 1% tolerance resistors. These resistors have five color bands: four color bands show the value plus a brown color band at one end that is wider than the others. The wide band indicates that it is a 1% tolerance resistor.
 - Sort the remaining 1/4 watt resistors by value. If the color bands are difficult to read, use a DMM (digital multimeter) to verify

their values. Tape them to a piece of paper with the values labeled.

Place the circuit PCB with the silk-screened side up and the cutout to your left as shown in Figure 13. The lettering ELECRAFT XV432 TRANSVERTER RF BOARD in lower right quadrant will read right side up. All of the remaining parts will be installed on the top, silk-screened side of the PCB.

 Save the longer clipped leads from the following resistors. You will use several of them to make jumpers and test points later.

Install the 1-watt resistors listed below. Space each resistor about 1/16" (1.5 mm) above the PCB by placing the long end of one of the right-angle brackets between the resistor and the PCB until the resistor is soldered in place (See Figure 15). The objective is to leave space for air to flow around the resistor. The resistors that should be spaced above the PCB are shown by a double silk screen outline.

- R16, 120 ohm (brn-red-brn) near U1 in the upper left quadrant of the PCB.
- R12, 180 ohm (brn-gry-brn) or (181J)
- R21, 820 ohms (821), next to R16.
- R19, 180 ohm (brn-gry-brn) or (181J), next to U5 at the center of the PCB.
- R8, 180 ohm (brn-gry-brn) or (181J) in the lower right quadrant.

PLACE RIGHT-ANGLE BRACKET UNDER EACH RESISTOR UNTIL IT IS SOLDERED IN PLACE

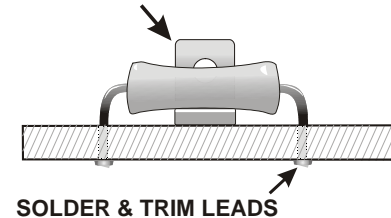

Figure 15. Spacing the 1-watt and 3-watt Resistors above the PCB.

Install R24, 68 ohm (68), 2-watts, in the lower left quadrant. Space it about 1/16" (1.5mm) above the PCB just like you did for the 1-watt resistors.

Install the following 3-watt resistors above R21 near the center of the PCB. Space each resistor about 1/16" (1.5 mm) above the PCB just like you did for the 1-watt resistors.

__R20, 160 ohm (160) ⇒ __R26, 160 ohm (160)
__R27, 160 ohm (160)

Install the 1/4-watt 1% tolerance resistors listed below in the lower left quadrant of the circuit PCB. Place these and all of the rest of the resistors directly against the PCB.

__R35, 5.11k (grn-brn-brn-brn) ⇒ __R31, 15.0k (brn-grn-blk-red)
__R30, 7.5k (vio-grn-blk-brn) ⇒ __R32, 3.92k (or-wht-red-brn)

Install resistor R41, 100k (brn-blk-yel), 1/4 watt in the lower left quadrant.

Install the 1/4-watt resistors listed below in the upper left quadrant.

__R1, 10k (brn-blk-org) ⇒ __R11, 1k (brn-blk-red)

Install the 1/4-watt resistors listed below in the upper right quadrant.

__R23, 100k (brn-blk-yel) ⇒ __R6, 240 ohm (red-yel-brn)

Install the 1/4-watt resistors listed below in the lower right quadrant. Start with R4, which is near the circle for OV1 work clockwise.

__R4, 5.6k (grn-blu-red) ⇒ __R5, 5.6K (grn-blu-red)
__R34 (on the right edge of the PCB), 100k (brn-blk-yel)
__R25, 56 ohm (grn-blu-blk) ⇒ __R33, 10k (brn-blk-org)

Install the following 1/4-watt resistors at the center of the PCB:

__R18, 620 ohm (blu-red-brn) ⇒ __R40, 22k (red-red-org)
__R42, 4.7 ohm (yel-vio-gld)

Install the following 1/4-watt resistors in the lower left quadrant near the cutout:

__R28, 1k (brn-blk-red) ⇒ __R29, 56 ohm (grn-blu-blk)

Locate the silk-screened space for D5 in the upper right quadrant of the PCB.



Diodes must be oriented correctly. A black band around the diode indicates the cathode end. Install each diode so the cathode end goes to the square solder pad and the band is oriented to match the silk-screened outline (see Figure 16 below). If a diode has more than one band, the widest band indicates the cathode end.



Figure 16. PCB Diode Orientation Guides. The cathode always goes to the square solder pad on the PCB.

Install D5 (1N4007) in the upper right quadrant. Position it against the PCB with the banded end of the diode aligned with the banded end of the PCB outline. Save the excess leads when you clip them.

Sort the small glass diodes by type. If necessary use a strong magnifier to read the tiny numbers printed on the glass body. Tape each group to a piece of paper marked by the type number.

- 1 ea. 1N5235
- 4 ea. 1N5711
- 10 ea. 1N4148

Install zener diode D3 (1N5235) in the upper left quadrant of the PCB near R12. Position it against the PCB with the banded end aligned with the banded end of the PCB outline.

Install the 1N5711 diodes in the lower right quadrant of the PCB. Place each diode against the PCB with the cathode band oriented as you did in the previous steps.

__D7 __D8 __D2 __D18

Install the 1N4148 diodes listed below. Start with D1, which is near resistor R1 in the upper left quadrant of the PCB and work clockwise around the PCB to D17 in the lower left quadrant.

__D1 ⇒ __D12 __D6 __D9 __D13
__D14 ⇒ __D15 __D16 __D4 __D17

 **In the following steps you will install molded inductors. These inductors look much like resistors but the color codes read differently. The color codes on the inductors read from the center to the end instead of from the end towards the center like resistors.**

Install molded inductor L8, 15 μ H (brn-grn-blk) in the upper right quadrant of the PCB.

Install molded inductor L9, 0.47 μ H (yel-vio-silver) near the circular outline for OV1 between the upper and lower right quadrants.

Install molded inductor L22, 0.1 μ H (brn-blk-silver) in the lower right quadrant.

Install molded inductor Z3, 0.1 μ H (brn-blk-silver) in the lower left quadrant.

Install molded inductor L2, 0.1 μ H (brn-blk-silver) in the upper left quadrant.

Install transistor Q6 (PN2222) next to R21 at the center of the PCB. Orient the transistor as shown by the silk-screened outline on the PCB.



Check each capacitor's labeling carefully to ensure the values agree with the numbers shown in parenthesis.

Install the monolithic capacitors listed below near Q6 at the center of the PCB.

__C68, .047 μ F(473) ⇒ __C67, .01 μ F (103)
__C64, .01 μ F (103) ⇒ __C65, .22 μ F (224)
__C10, .01 μ F (103) ⇒ __C9, .01 μ F (103)

Install the monolithic capacitors listed below. Start with C38 in the upper left quadrant and work across the top of the PCB into the upper right quadrant.

__C38, .01 μ F (103) ⇒ __C29, .047 μ F(473)
__C37, .01 μ F (103) ⇒ __C35, 10 pF (100)
__C36, μ F .01 (103) ⇒ __C34, .01 μ F (103)
__C39, .001 μ F (102)

Install the capacitors listed below near the circle for OV1 between the upper and lower right quadrants.

__C14, 15 pF (15) or (150) ⇒ __C14A, 15 pF (15) or (150)

Install monolithic capacitor C12, 18 pF (18) or (180) near the circle for OV1 between the upper and lower right quadrants.

Install the monolithic capacitors listed below. Start with C71 on the edge of the PCB in the lower right quadrant and work from right to left across the lower part of the PCB.

__C71, .01 μ F (103) ⇒ __C57, 100 pF (101)

__C19, .01 μ F (103)

Install disc ceramic capacitor C18, 4.7 pf (4.7) near C17 in the lower right quadrant of the PCB.

Install the capacitors listed below in the lower right quadrant in the area marked 28 MHZ IF BANDPASS FILTER. The lead spacing of these capacitors may be narrower than the hole spacing on the PCB. If necessary, form the leads to avoid stress on the capacitor when they are inserted in the PCB. **Do not force the capacitors down against the PCB.** Capacitors with lead spacing narrower than the hole spacing may sit about 1/16" (1.5 mm) above the PCB as shown in Figure 17 .

__C55, 180 pF (181) ⇒ __C54, 150 (151) pF

__C53, 22 pF (220) or (22) ⇒ __C52, 150 (151) pF

__C56, 180 pF (181)



The capacitors shown are typical.
Other styles may be supplied.

Figure 17. Installing I.F. Filter Capacitors.

Locate the rectangular 2-6 pF trimmer capacitor C1. Turn the trimmer over and note that there is a small dot near one of the terminals.

Install C1 in the space provided in the upper left quadrant with the terminal nearest the dot toward the space for L1. The outline on the PCB may not match the shape of the trimmer. The temporary jumper across the solder pads for L1 should still be in place on the PCB.

Use a discarded lead to create test point TP3. Two solder pads for TP3 are directly below SMD resistor R17 in the upper right quadrant of the PCB. Bend the lead in a “U” shape and insert it in the pads indicated with a line between them on the PCB. The loop formed should rise about 1/4” (4 mm) above the PCB. Solder the leads.

Use a discarded lead to create TP4 next to TP3, following the procedure described above. Solder the leads.

Make two ground test points just like you did for TP3 and TP4. Install them where indicated by ground symbols. One location is in the lower right quadrant above the “Elecraft” label and the other is in the lower left quadrant near the left edge of the PCB. Solder the leads.

Remove seven of the eight small relays (G6E-134P) from the carrier tube. If any of the pins are bent, straighten them carefully using long-nose pliers.

Place the relays below at the locations shown. They can only be installed one way. Do not solder the relays yet and do not clip or bend the relay leads.

Upper Right: __K8 __K9 __K7 __K4 __K5 __K6

Lower Left: __K2

Note that K1 is *not* installed at this time. It will be installed later.

Use a thin, hardcover book to hold the relays in place, then flip the PCB and book over together.

- Solder just two diagonally opposite corner pins on each relay.
- Turn the book back over and check each relay. If any relay is not flat against the PCB, re-heat the soldered corner pins while pressing it down against the PCB.
- Once all the relays are properly seated, solder the remaining pins. Take care to locate and solder all five pins on every relay. **Do not trim the relay pins.** Trimming the pins can cause mechanical stress which may reduce the life of the relay.
- Check the pins on the large relay (KLT1C12DC12). If any pins are bent, straighten them carefully using long-nose pliers.
- Install the main power relay (KLT1C12DC12) in the upper right quadrant. Solder two diagonally opposite corner pins. Check the relay to ensure it is flush against the circuit PCB. If necessary, reheat the soldered pins while pressing down on the relay.
- Solder all five pins on the main power relay. **Do not trim the relay pins.** Trimming the pins can cause mechanical stress which may reduce the life of the relay.
- Install resettable fuse F1 (G800) in the space provided next to relay K9. F1 may be oriented either way. Solder and trim the leads.
- Install a 3-terminal header at JP1 adjacent to relay K8. Put a shorting block over two pins of the header to provide a surface where you can place your finger to keep it straight and against the PCB. While holding the assembly, touch one of the pins on the bottom of the PCB with a soldering iron to tack-solder it in place. Check to ensure that the header is sitting vertically on the PCB (see Figure 10 on page 19). Reheat and adjust as necessary, then solder all three pins. **Do not hold the solder iron on the pins more than 1 or 2 seconds. Excessive heat will melt the plastic part of the header.**
- Remove the shorting block from JP1.

- Install the following 3-terminal headers:
 - JP2 next to relay K8.
 - JP3 next to relay K8.
 - JP4 near resistor R21.
 - JP5 near relay K6.
 - JP6 near relay K6.
- Install JP9 next to K4 and K5. JP9 requires one 2-terminal header and one 3-terminal header.
- Install the 100 k-ohm (104) potentiometer R10 (Power Cal) in the upper left quadrant of the PCB. The center lead goes toward the beveled end of the silk screen outline (see Figure 18). The shoulders on the leads should touch the top of the PCB.



Figure 18. Installing R10. Orient the center pin toward the beveled end of the silk-screened outline.

- Spread the leads on R10, if needed, to hold it in place then solder and trim the leads.
- Install 100 ohm PC board potentiometer R22 (101) just as you did R10. R22 is below the three 160-ohm 3-watt resistors near the center of the PCB.

Install PC trimmer potentiometer R39, 1 K-ohm (102) near the center of the PCB as you did R10 and R22.

Locate the 25-ohm PC board trimmer potentiometer R13. This potentiometer may not show a value. Confirm the value with your DMM. The value your DMM reports may not be exactly 25 ohms.



After removing the temporary jumper in the following step, amplifier Q3 will be exceptionally vulnerable to ESD damage until R13 is in place. Take ESD precautions (see page 3) when handling.

Remove the temporary jumper from the pads for R13 in the upper left quadrant of the PCB near D3 and install the 25-ohm trimmer potentiometer R13. This trimmer will sit down against the PCB.

Install 4-pole DIP switch SW1 in the space provided in the lower left quadrant of the PCB. The DIP switch may not have a notch at one end to line up with the silk-screened outline. Orient the switch so that the ON positions are on the side with the silk-screened numbers. If you aren't sure, use your DMM to check the orientation of the switch assembly so there is continuity through each switch when the toggle is toward the silk-screened number on the circuit PCB.

Bend the leads of voltage regulator U4 (78M05C) to fit in the space provided in the lower left quadrant of the PCB as shown in Figure 19. Bend the leads around the shaft of a small screwdriver to create smooth bends. Avoid making sharp bends in the leads.

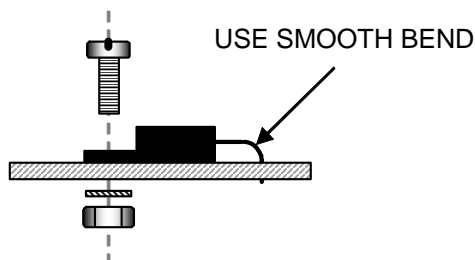

Figure 19. Installing Voltage Regulator U4.

Insert U4's leads into the holes. Secure it with a zinc or stainless steel 4-40 x 5/16" (8 mm) screw, #4 internal-tooth lock washer and 4-40 nut as shown. The metal tab on the transistor should rest directly against the metal foil on the circuit PCB.

Solder all three leads to U4 on the bottom side of the PCB and trim them short.

Install two 22 μ F, 25 VDC electrolytic capacitors near the notch on the left side of the PCB. **Be sure to observe polarity. The longer positive lead goes in the square solder pad with a + silk-screened next to it.**

__C26

__C60

Locate diodes D10 and D11. They are square, red LEDs identical to the ones you installed on the front panel PCB.

Locate the positions for D10 and D11 on the PCB, near the circle for OV1 in the upper right quadrant. Note that the square solder pad for D10 is to the left and the square solder pad for D11 is to the right. The diodes *must* be installed turned 180 degrees with respect to each other.

Position diode D10 on the PCB with the long lead through the square pad on the left and the short lead through the round pad. Position the body of the LED directly against the PCB within the silk screen outline and spread the leads under the PCB to hold the diode in place.

Solder one lead on the bottom of the PCB. Check to be sure the LED is still positioned directly against the PCB. Reheat and adjust the LED as necessary, then solder and trim both leads.

Position diode D11 on the PCB with the long lead through the square pad on the right, opposite the orientation of D10. Solder and trim the leads as you did for D10.

- Locate the two unshielded solenoidal inductors:
 - L4 has an orange body with four turns.
 - L19 has a red body with 2-1/2 turns.
- Use the alignment tool to *remove* the tuning slug from L19. This slug will not be used.
- Install L19 in the upper right quadrant next to the circle for OV1. It can be inserted either way. Do not try to bend the terminals. Tack-solder one terminal while holding the coil in place. Ensure it is sitting against the PCB, then properly solder both terminals.
- Use the alignment tool to ensure the tuning slug moves smoothly in L4 (Leave the slug in this inductor).
- Install L4 in the upper right quadrant next to the circle for OV1.
- Locate the five shielded inductors. Check the inductors as follows:
 - Use the inductor alignment tool to exercise the slug in each inductor. If the alignment tool fits tightly, insert it from the bottom to avoid pushing the inductor out of the shield. The slugs in some inductors turn very stiffly at first. Run the slug up and down through the coil to ensure it runs smoothly, then position the slug near the top of the coil.
 - Check the two leads and the two tabs on the case of each inductor. If they are bent, straighten them carefully using long nose pliers.



Do not test or change the adjustment of the three-section helical filters used for FL1 and FL2.

- Check the color of the plastic insert in each inductor:
 - Three inductors have gray inserts. They are L15, L16 and L17.
 - Two inductors have orange inserts. They are L3 and L5. Set these inductors aside for now.

- Locate the positions for L15, L16 and L17 in the I.F. Bandpass filter in the lower right quadrant.
- Be sure you have the three inductors with the gray inserts. Position each inductor on the PCB so its tabs and pins protrude through on the bottom. The inductors can be positioned either way. Ensure that the shoulders of the tabs are against the top of the PCB, and then bend the tabs toward each other until they are flat against the PCB to hold the inductor in place.
- Solder the two tabs and the two pins on each inductor.

__L16 ⇒ __L15 __L17
- Install L3 and L5 (orange inserts) so their tabs and pins protrude through on the bottom (lower right quadrant). The inductors can be positioned either way. Ensure that the shoulders of the tabs are against the top of the PCB, and then bend the tabs toward each other until they are flat against the PCB to hold the inductor in place.
- Solder the two tabs and the two pins on each inductor.

__L3 __L5
- Locate the three-section shielded helical filters, FL1 and FL2. *Do not test the adjustment screws.* These inductors should be close to the proper adjustment as supplied. You'll make final adjustments when you do the alignment and test procedures on your completed transverter.
- Position each of the filters in the spaces provided for FL1 and FL2 in the lower left quadrant. The filters will only go in one way. Ensure the shoulders of the tabs are against the PCB, then bend the tabs to hold the filter in place. Bend the tabs away from the nearest solder pads to avoid the possibility of creating a short.
- Solder the six tabs and six pins on each filter.

__FL1 __FL2

Locate the solder pads for choke L7 on the left side of the PCB next to electrolytic capacitor C26 near the notch. Choke L7 consists of a bare wire passing through two ferrite beads as shown in Figure 20.

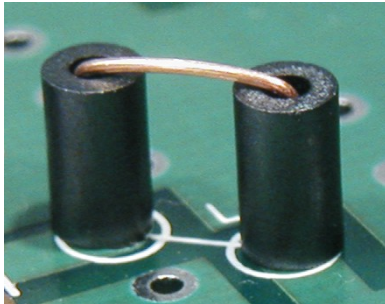



Figure 20. Installing L7.

Strip the insulation from 3" (7.5 cm) of the #24 solid insulated wire provided.

Bend the wire into a U shape to match the spacing of the holes on the PCB. Place a bead on either side of the bend.

Thread the ends of the wires through the solder pads for L7. Make sure the beads are sitting vertically on the PCB over each hole and bend the leads on the bottom of the PCB to hold the assembly in place.

Solder both leads and trim them as short as possible.

 After removing the temporary jumper in the following steps, amplifier Q3 will be exceptionally vulnerable to ESD damage until L1 is in place. Take ESD precautions (see page 3). Wear a grounded wrist strap or, as a minimum, touch an unpainted, grounded object before touching the PCB.

Cut a 1-1/4 inch (3.2 cm) length of the bare 16 gauge tinned wire provided. Use your needle nose pliers to straighten the wire.

Remove the temporary jumper from the position for L1, then shape the 16-gauge wire to fit between the pads for L1 (upper left quadrant) as shown in Figure 21. Use one of the terminal shorting blocks lying on its side to space the wire above the PCB.

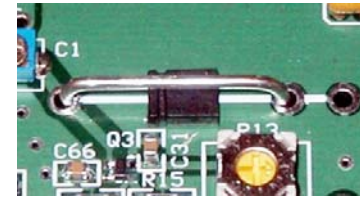

Figure 21, Inductor L1 Positioned for Soldering. Shorting Block on Its Side Provides Proper Spacing.

Ensure the wire is parallel to the PCB and spaced away from it by the thickness of the shorting block, then solder it in place from the top of the PCB. Take care not to touch or R13 or C1 with your iron.

Remove the shorting block, turn the PCB over and clip the excess leads as short as possible.

Install transistor Q4 (620) in the space provided near diodes D7 and D8 in the lower right quadrant as follows:

- Orient the tab over the heavy line on the silkscreen outline, and insert the transistor up to the shoulders on the leads.
- Bend the leads to hold the transistor in place, then solder trim the leads on the bottom of the PCB.
- Tilt the transistor back at an angle so the top is not more than 7/8" (2.2 cm) above the PCB to provide clearance between the tab and the transverter cover when the unit is assembled. (See Figure 22).

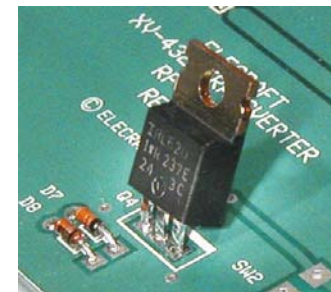

Figure 22. Installing Transistor Q4.



The following transistor is particularly sensitive to electrostatic discharge (ESD) damage. Take ESD precautions (see page 3). Wear a grounded antistatic wrist strap or, as a minimum, touch an unpainted, grounded object before handling Q5.

Install transistor Q5 (2N7000) in the lower right quadrant (at the right edge of the PCB).

Install two 2-pin header connectors next to Q5.
 __JP8 __JP7



In the following steps you will install two very similar voltage regulators. Be sure to read the numbers and install the correct part in each location.

Install voltage regulator U2 (78L09) in the lower right quadrant of the PCB.

Install voltage regulator U3 (78L05) near the center of the PCB.



Read the following step completely and refer to Figure 23 before installing Q1. Q1 is installed differently from other transistors in this kit.

Install transistor Q1 (MPS918) in the upper right quadrant near the circle for OV1 as follows:

- Locate the Teflon tubing and cut it to a length of 3/8" (8 mm).
- Slide the 3/8" (8mm) length of Teflon tubing over the center lead of transistor. It must touch the body of Q1.
- Position Q1 so that the Teflon tubing acts as a spacer to hold the transistor above the PCB (see Figure 23). One end of the tubing should contact the bottom of Q1's case and the other end should rest against the top of the PCB. Spread the leads on the bottom of the PCB to hold Q1 in place.
- On the bottom, solder and trim the leads as short as possible.



Figure 23. Installing Q1 with Teflon Spacer.

Install the DPDT power switch at SW2 in the lower right corner of the PCB. Orient the switch so the pushbutton shaft extends out over the edge of the PCB. Be sure the two feet on the bottom of the switch are resting against the PCB before soldering.

Install crystal Y1 within the rectangular outline inside the circle for OV1 in the upper right quadrant. The crystal may be oriented either way. Be sure the crystal case is sitting directly against the PCB. **Do not hold your soldering iron on the leads more than 2 or 3 seconds maximum. Excessive heat may damage the crystal.**

If you purchased the optional crystal oven with your transverter (Elecraft part number E980076) install it now as follows:

- Position the oven down over the crystal so the three leads on the oven pass through the +, - and NC holes in the PCB. The oven will only go on the crystal one way.
- Bend the leads over on the bottom of the RF PCB to hold the oven in place, then tack-solder one lead.
- Check to be sure the oven fully seated down over the crystal and against the PCB. If necessary, reheat the soldered lead and adjust its position.
- Solder and trim all three leads.

- Locate the two RCA Jacks, J3 and J4. Use your flush cutters to trim off the two small plastic feet on each jack. Be sure they are cut flush so the jacks will sit squarely against the PCB when installed in the next step.

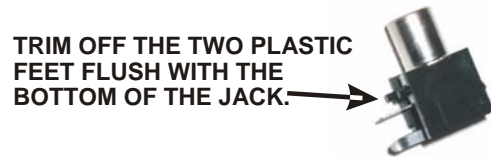

Figure 24. Preparing the RCA Jacks for Installation.

- Install the two RCA jacks at the top of the PCB. Solder one pin first then check to be sure the jack is sitting flat against the PCB. If necessary, reheat the solder while pressing down on the jack. Solder the second pin then trim the leads.

__J5

__J4



J8, installed in the next step, is not required if you are building your transverter to use a common transmit and receive antenna. J8 is needed only if you plan to use separate (split path) transmit and receive antennas. It won't hurt to install it in any case.

- Install three BNC jacks at the top of the PCB. Line up the two supports and the two small conductor pins with the holes and gently press the connectors down until the four plastic pins on the jack rest directly against the PCB. Solder one of the large pins, then check the position. If necessary, reheat the solder while pressing down on the jack. After soldering all four pins, trim off the excess length of the small pins.

__J8

__J2

__J3

- Install the DB-9 female connector at J6 and solder the pins including the two larger mounting pins.

- The Anderson power connector is held in place by two heavy copper wires soldered to the PCB (See Figure 25). Prepare and install the connector as described in the following steps.

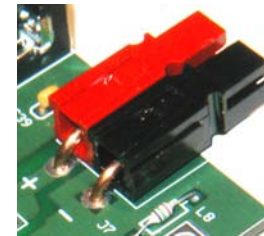

Figure 25. Installing J7.

- Cut the length of #14 copper wire provided in half.
- Solder each length of the #14 copper wire into the crimp terminal end of an Powerpole® contact. **Solder, do not rely on a crimp connection. Take care to keep solder off of the contact.**
- Orient each contact as shown in Figure 26 and push it into a shell until it “clicks” in place. Tug on the wire to be sure it is locked in place. If the contact comes out, you probably have it in upside down.

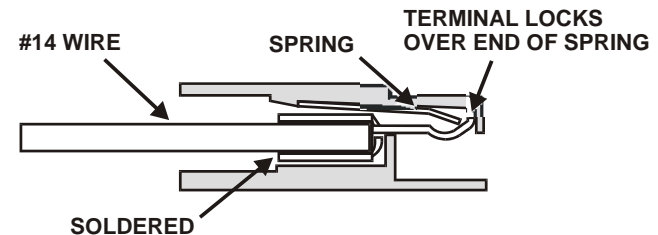

Figure 26. Inserting Terminal into Anderson Connector Housing.

Inspect the end of each connector. You should see the contact pressing up against the end as shown in Figure 27. If necessary, press the contact in from the rear until it reaches the end. **If you don't get the contact pushed all the way in so it locks over the end of the spring, it will not make reliable contact with the mating connector.**

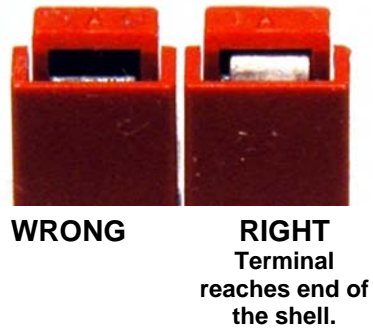

Figure 27. Verify Contact is Fully Inserted.

Orient the housings with dimpled side up so that the red and black housings are over the colors marked on the PCB exactly as shown in Figure 28. **Be sure the housings are oriented as shown. If they are upside down they will not mate to the connectors on the power cord.**

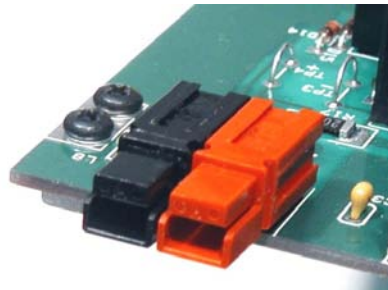

Figure 28. Orienting J7 on the RF PCB.

Look closely at the sides of the housings. Each has a small tongue on one side and a groove on the other. Slide the two shells together engaging the tongue in the groove. Be sure they are fully meshed. No roll pin is needed to lock the shells together.

Bend the copper wire at right angles to the housings so that when it is placed in the holes on the PCB, the housings lie against the PCB within their outline as shown in Figure 28. **Be sure the red housing is on the + side and the shells are oriented as shown.**

Solder the wires in place and cut them as close to the PCB as possible.

Cut a 3/4" length of the 16 gauge tinned wire.

In the upper left quadrant, solder the wire in the pad marked with an antenna symbol so that 1/2 inch of the wire sticks up vertically (see Figure 29). Trim the wire as close as possible to the bottom of the PCB.

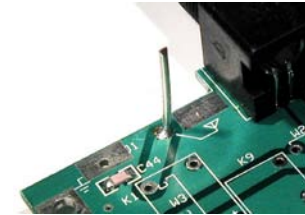



Figure 29. PCB Antenna Connection.

Unwrap the cabinet back panel. That is the panel with a row of holes for the connectors.

 **Good electrical contact between all of the chassis parts is essential for optimum shielding and system noise figure.**

Remove paint overspray from the *inside* surface of the cabinet back panel in the following locations. Sandpaper is provided for this purpose.

- Around the four screw holes for the ANT connector.
- Around the two screw holes for the CONTROL connector.
- Around the four screw holes at the corners of the back panel.

□ Mount antenna connector J1 on the cabinet back panel using four 5/16" 4-40 pan head zinc or stainless screws, lock washers, nuts and *two* ground lugs as shown in Figure 30 and Figure 32. Be sure both ground lugs on the lower screws face upward as shown. Be sure all four screws are tightened.

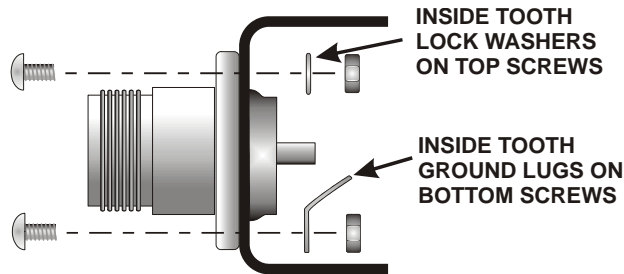

Figure 30. Mounting the Antenna Connector J1 on the Back Panel.

□ Install four 2-D fasteners on the corners of the RF PCB. The 2-D fasteners go on the bottom of the PCB. Line up the offset holes of each 2-D fastener so the side of the connector is flush with the edge of the PCB (see Figure 31). Secure each connector to the PCB with two black 3/16" (4.8 mm) pan head screws and *split* lock washers.

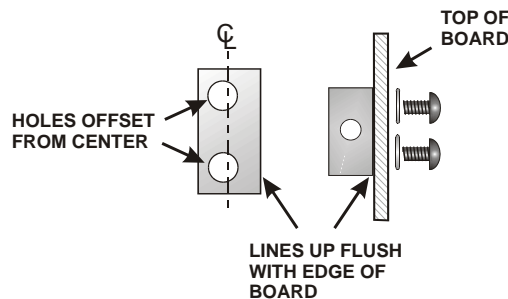

Figure 31. 2-D Fasteners.

□ Test fit the back panel with J1 attached to the rear of the PCB. Slip the cover over the jacks until the two holes on the bottom edge line up with holes on the 2-D fasteners nearest the edge of the PCB and attach it with two pan-head 3/16" (4.8mm) screws.

□ Note the position of the two ground lugs on J1 relative to the tinned pads on the edge of the PCB ground plane. Remove the back panel and adjust the ground lugs as follows:

- Trim the lugs to length so they just cover the tinned PCB surface. Be sure the lug nearest the corner does not touch SMD capacitor C44.
- Bend the lugs down so they rest against the tinned areas on the PCB when the rear panel is secured to the 2-D fasteners (See Figure 32). This is easiest to do if you remove the panel to adjust their positions. Do not solder until instructed to do so.

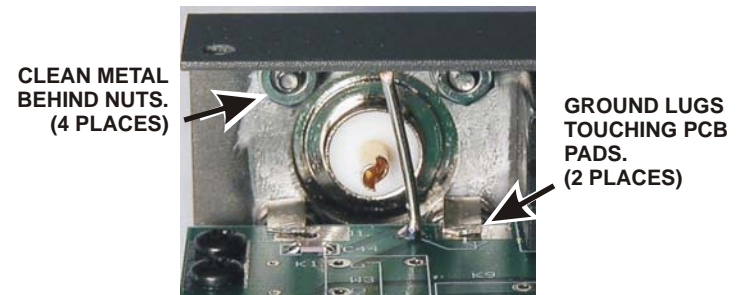

Figure 32. Mounting Antenna Connector J1.

⚠ Do not force the threads when assembling the modular chassis elements. Screw holes will sometimes not align perfectly. When that happens loosen the other screws slightly so the parts can move as needed to align the holes, then tighten all hardware.

□ Attach the two DB-9 male-female standoffs to the Control connector. Use a #4 inside-tooth lock washer between each standoff and the rear cover.

□ Slip the finish lock washers and nuts over the BNC connectors and tighten them.

- Solder the two ground lugs on antenna connector J1 to the PCB (See Figure 33).

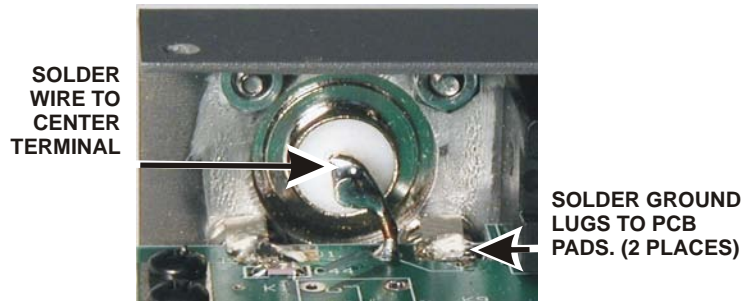

Figure 33. Antenna Connection J1 Installation.

- Bend the 16 gauge wire you previously soldered in the PCB antenna pad so that it rests against the antenna connector center terminal, then solder. Keep this lead as short as possible as shown in Figure 33. Trim off excess wire.
- Strip the insulation from a 2" (5 cm) length of the #24 hookup wire.
- Wrap the wire around the alignment tool twice as shown in Figure 34 to form a two-turn self-supporting coil. Use the thicker portion at the end of the alignment tool with the hex driver exactly as shown, *not* the larger end with the screwdriver tip. Instead of the alignment tool, you can use the shaft of an 9/64-inch (or 3.5 mm) drill bit.

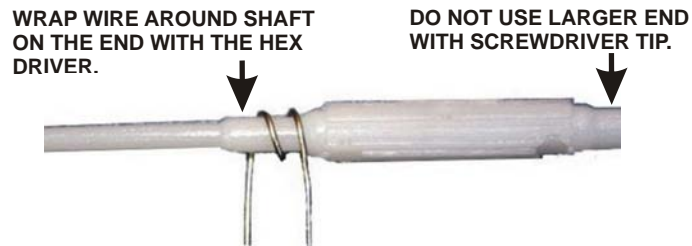

Figure 34. Winding L10 on the Alignment Tool.

- Position the coil in the pads for L10 in the upper left quadrant as shown in Figure 35.
 - Adjust the coil so the turns are even and the wires go straight down into the pads on the PCB as shown. The spacing of the pads defines the correct length of the coil.
 - Use a jumper shorting block laying on its side to set the correct height of the coil above the PCB.
- Solder the coil in place. Remove the shorting block from under L10 and clip the leads as short as possible on the bottom of the PCB.

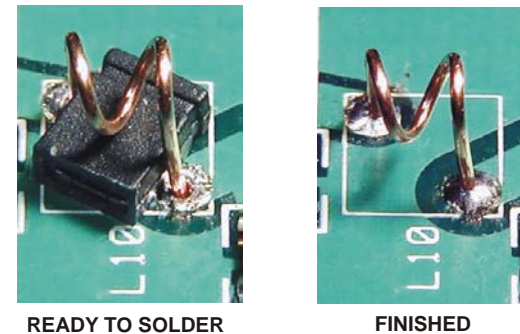

Figure 35. Installing L10.

- Position relay K10 (G6B-1174P) in the upper left quadrant near antenna connector J1. Hold it in place and tack-solder pins at opposite corners.
- Check to ensure the relay is against the PCB. If necessary, reheat the corner pins while pressing down on the relay. When it is properly positioned, solder all four pins. Do not trim the pins.



In the following steps, you'll choose whether to set up your transverter for use with a single antenna and feed line or for use with separate transmitting and receiving antennas and separate feed lines. Do only *one* of following two steps.

Antenna Option 1: If you are building your transverter for use with separate (split path) transmit and receive antenna connections and separate feed lines, use discarded leads to form jumpers across W2 and W3 in the upper left quadrant as shown in Figure 36. Solder the jumpers on the bottom side of the PCB to avoid touching the relay or trimmer C1 with your iron.

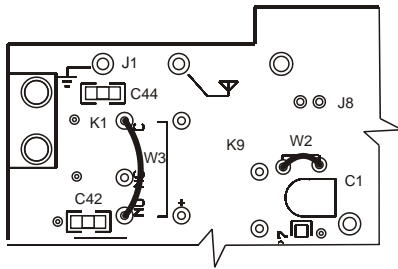

Figure 36. Installing W2 and W3 for Split Path (Separate Transmit and Receive Antenna) Operation. Do *Not* Install Relay K1.

Antenna Option 2: If you are building your transverter for use with a single antenna used for both transmit and receive, do the following:

- Verify that jumpers W2 and W3 are *not* installed in the spaces shown in Figure 36 (above).
- Install the remaining relay K1 (G6E-134P) directly behind the antenna connector. Use the same technique described for relay K10. Do *not* trim the leads after soldering.

Locate the cooling fan. Inspect the sides of the fan and find the two arrows molded into the plastic. One identifies the direction of fan rotation and the other indicates the direction of airflow when the fan is operating.

Position the fan over the outline at the center of the PCB so the air will flow up and away from the PCB. The wires should exit the fan housing nearest the lower right quadrant of the PCB (see Figure 37).

Attach the fan to the PCB using four 5/8" 4-40 pan head screws inserted from the top and secured with 4-40 inside tooth lock washers and nuts on the bottom of the PCB.

Separate the two conductors of the fan lead. They will pull apart into separate insulated wires once the web of insulation is cut between them at the end. Take care to start the cut in the center so that pulling them apart doesn't expose one of the conductors along its length. Pull the wires apart to a point about 1" (2.5 cm) from the fan housing.

Cut and strip the wire with a black stripe to fit in solder pad B near the corner of the fan. Be sure you place the wire in solder pad B. Solder pad A nearby is *not* used.

Route the red wire alongside relay K6 and then pass the through the hole in the circuit via to the bottom of the PCB as shown in Figure 37. Pull all the wire through the via and position the lead as shown.

RED WIRE PASSES THROUGH HOLE IN CIRCUIT VIA TO BOTTOM SIDE OF BOARD. PULL THE EXCESS WIRE THROUGH THE HOLE.

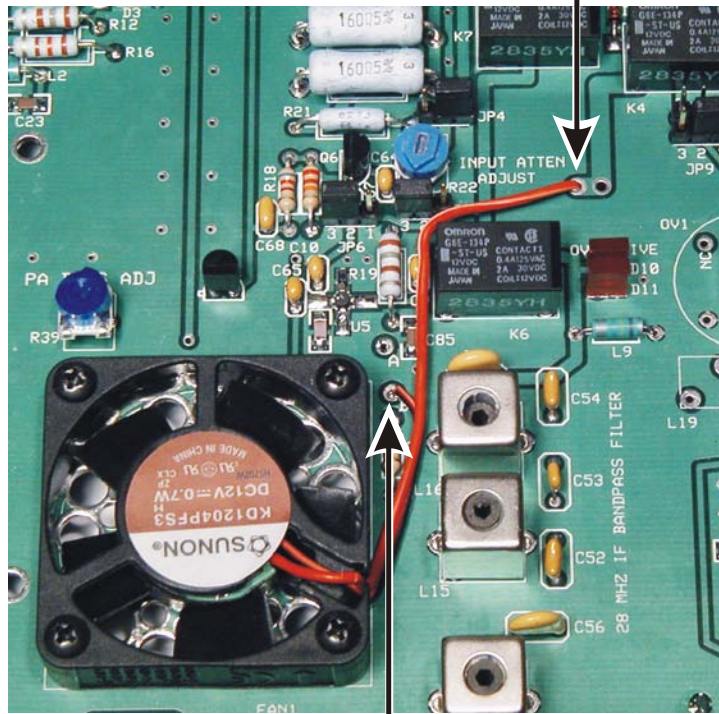

BLACK WIRE SOLDERED TO PAD B.
Figure 37. Installing Fan.

- On the bottom of the board, route the lead to the solder pad at relay K5 as shown in Figure 38. Cut and strip the lead, and solder it to the relay pin. The relay pin provides an easy attachment point since there is no solder pad for this lead.

CORNER PIN OF K5 THAT CONNECTS TO CATHODE OF DIODE D15.

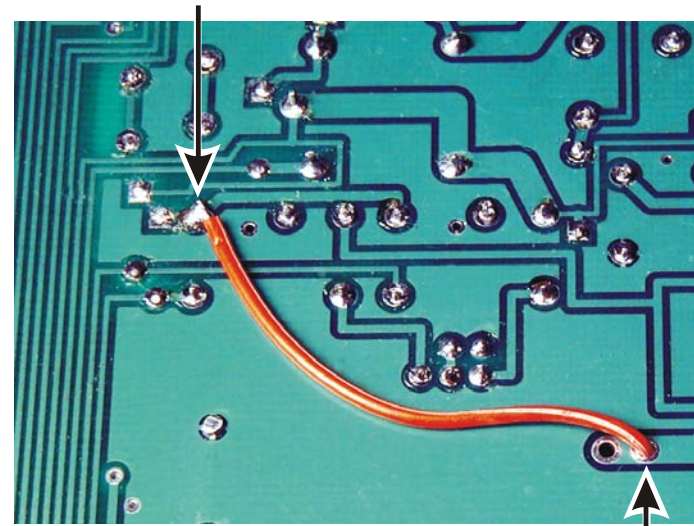

RED FAN WIRE FROM TOP OF PCB

Figure 38. Fan Wire Routing on Bottom of PCB.

- Locate the bottom cover of your transverter. This is the plate with *two* sets of cooling air holes.
- Inspect the inside surface of the cover. Remove any masking tape you find.
- If you purchased the optional feet and bail for your transverter, install them on the bottom cover now.



In the following steps you will install the hardware that attaches the RF power module to the bottom cover. Follow the steps carefully to ensure the module makes good thermal contact with the bottom cover and the leads line up properly with the RF PCB. The completed hardware assembly is shown in Figure 42.

- On the inside surface of the bottom cover find the four holes along one side that match the holes in the heat spreader. They are between the two groups of cooling holes in the cover.
- Test-fit the larger of the two thermal conduction pads so that the holes in the pad line up with the holes in the cover. Orient the pad so it does not hang over the edge of the bottom cover.
- Lift the thermal conduction pad and clean the surface of the bottom cover under the pad using sandpaper, a sharp knife or other tool if needed. The thermal conduction pad must rest against clean metal.
- Clean the paint off of the inside surface of the bottom cover around the screw holes in the four corners where the 2-D fasteners will attach it to the RF PCB.
- Inspect the edges of the heat spreader and remove any burrs with the edge of a flat-blade screwdriver, knife or small file. Note that two of the holes in the heat spreader are tapped and two are not.
- Replace the larger of the two thermal conduction pads over the clean metal area on the inside of the bottom cover so that the holes in the pad line up with the holes in the cover. Be sure the pad does not hang over the edge of the bottom cover.
- Place the heat spreader on the thermal conduction pad so the screw holes line up. The unthreaded holes should be closest to the edge of the bottom cover. Put a 1/2" (12.7 mm) pan head screw through each unthreaded hole with the head on the bottom cover. Place a nut on each screw and finger tighten to hold them temporarily.

- Insert two black 3/16" (4.8 mm) pan head screws through the bottom cover into the threaded holes in the heat spreader. Tighten the screws.
- Lay the bottom cover on a clean, smooth surface with the heat spreader facing up.
- Remove the nuts from the long screws but do not remove the screws. If you have installed feet on the bottom cover, place a small book that fits between the feet under the cover so the long screws do not fall out.
- Place the smaller thermal conduction pad over the screws. Orient the pad so it does not hang over the edge of the heat spreader. If the pad is too large no matter which way you orient it, use a sharp knife or scissors to trim it. When the RF power module is installed it must fit as shown in Figure 39.



Observe the ESD precautions on page 3 before handling the RF power module.

- Position the RF power module on the two screws as shown in Figure 39. Be sure the thermal conduction pad on the heat spreader is resting directly against the bottom of the RF power module.
- Place a flat washer on each screw as shown in Figure 39.



Figure 39. RF Power Module and Flat Washers in Place on the Heat Spreader.

Slide the PCB under the leads on the RF power module and over the screws until they pass through the holes in the PCB (see Figure 40). You can rock the RF power module slightly on the screws and bend the leads up as needed to slip the PCB under them and over the tops of the mounting screws.

Place an internal-tooth lock washer and nut on each screw and tighten them finger tight.



Figure 40. RF PCB attached to the RF Power Module Screws.

Pick up the entire assembly and secure the four corners of the bottom cover to the 2-D fasteners with 3/16" (4.8 mm) black screws (Figure 41). The rear panel screws should already be in place. The other holes will secure the front and side covers in later steps.

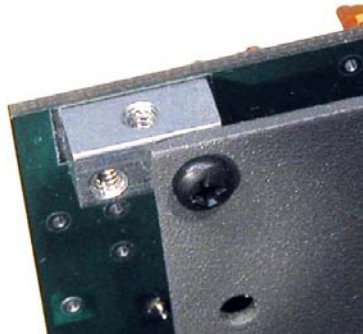

Figure 41. Bottom Cover Attached to a 2-D Fastener.

Inspect the RF power module to be sure you have the module and hardware installed exactly as shown in Figure 42.

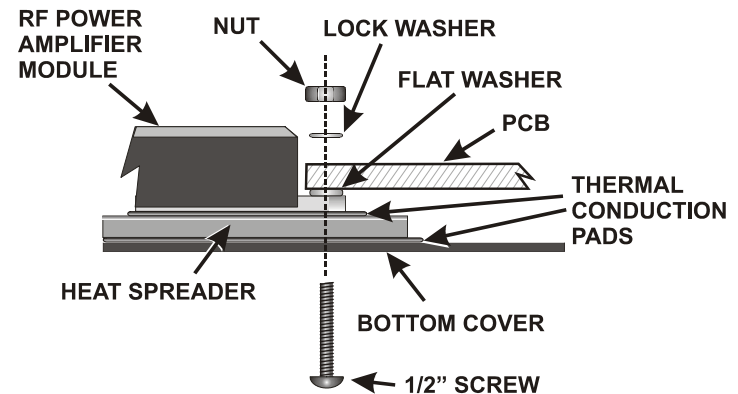



Figure 42. RF Amplifier Module Mounting Hardware.

Form the RF power module leads so they rest flat on the PCB solder pads. If necessary, loosen the nuts slightly to allow the module to move within the limits of its screw holes.

Hold the RF Power module in place and tighten both screws and nuts to secure it.

 Be sure the four screws holding the RF Power module and heat spreader are tightened securely to ensure good heat transfer. Otherwise the RF Power module may overheat and fail.

Solder the RF power module leads to their corresponding pads on the PCB. Before soldering, trim the leads as needed so they do not extend beyond the solder pads.

Mount the two L brackets on the edge of the RF PCB (see Figure 14 on page 23). Place the shorter side of each bracket against the top of the RF PCB and secure it with a 3/16" (4.8 mm) screw and split lock washer.

This completes the assembly of your RF PCB. Go to Final Assembly in the next section.

Final Assembly

 Either wear a grounded antistatic wrist strap or touch an unpainted, grounded object before handling the processor (U1) in the next steps, or at any time you handle the front panel PCB unplugged from the RF PCB with processor U1 installed.

Remove processor U1 from its conductive foam packing and inspect the pins. The two rows of pins must be straight and parallel to each other to establish the proper pin spacing for insertion into the socket. To straighten the pins, rest one entire row of pins against a hard, flat surface. Press down gently and rock the IC forward to bend the pins against the flat surface into position as shown in Figure 43.

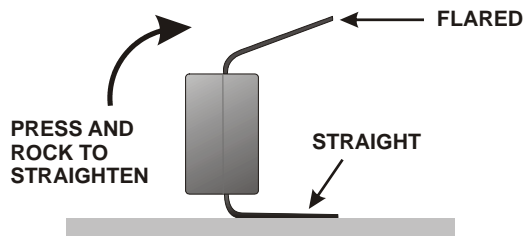

Figure 43. Straightening IC Pins.

Identify the end of the IC where Pin 1 is located. It will have a notch, a dimple or both at this end (see Figure 44).

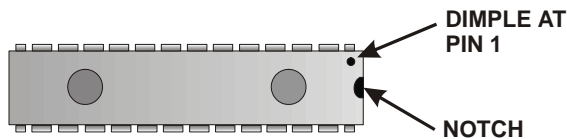



Figure 44. IC Orientation.

 When U1 is pressed into its socket, you must be careful to avoid jamming its pins. Make sure all the pins are lined up with the associated holes before pressing down on the IC. Watch the pins on both rows as you press down to be sure each pin goes straight down into its socket hole and does not bend in under the IC or outward alongside the socket. Realign each pin individually with its socket hole, if necessary.

On the front panel PCB, insert processor U1 in its socket with pin 1 or the notched end lined up with the notched end of the socket (the end farthest from the edge of the PCB). If necessary, repeat bending the pins as shown in Figure 43 until they fit in the socket without excessive binding against the sides. Be careful while pressing U1 into its socket not to bend or damage the power indicator LEDs on the front side of the PCB.

Insert plug P1 on the front panel PCB into J1 on the bottom of the RF PCB, then secure the front panel PCB to the two right angle brackets with 3/16" (4.8 mm) screws and split lock washers.

Unwrap the cabinet front panel and clean the metal around the mounting holes on the inside of the panel to ensure a good electrical contact with the 2-D fasteners.

Place the cabinet front panel face up on your work surface and attach the band label with two 2-56 screws. Orient the label with the lighter side upward so that the band identification reads correctly when viewed from the front.

Fit the front panel over the power pushbutton and power LEDs. Attach the front panel to the 2-D fasteners on the bottom of the RF PCB with two 3/16" (4.8 mm) screws.

- Press the key cap onto the On/Off switch shaft until it clicks in place.
- Attach a 2-D fastener to the each screw hole at the top corners of the front and rear chassis end panels with 3/16" (4.8 mm) screws. Be sure the widest side of each 2-D fastener is facing so the edge lines up flush with the edge of the panel as shown in Figure 45.



Figure 45. Attaching 2-D Fasteners to Cabinet End Covers.

- Attach the side panels using four 3/16" (4.8 mm) screws in each panel. You may need to loosen the other screws temporarily to line up the screw holes properly.

 In the following step be sure to orient the Anderson power connector shells exactly as shown. Otherwise, the connector will not mate with the connector on the transverter.

- Locate the two Anderson power connector shells. Orient them as shown in Figure 46 and slide them together so the tongue on one side fully engages the groove on the other half.

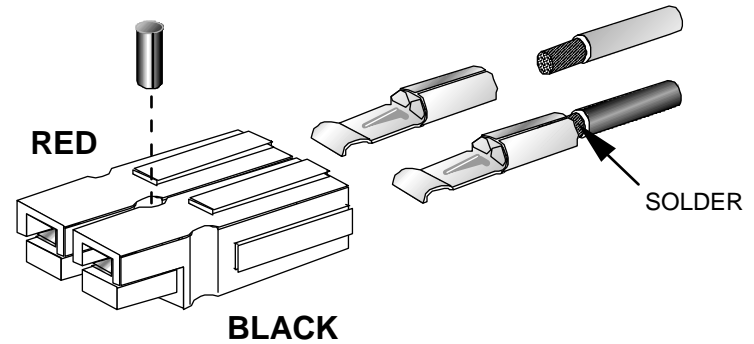



Figure 46. Power Cable Connector Assembly.

 Use only the supplied 12 AWG, 2-conductor stranded wire (red/black) for the DC power cable.

- Separate the two conductors at one end of the 12 AWG, 2-conductor cable. Remove 5/16" (8 mm) of insulation from the red and black wires at one end. Do not nick or cut off any of the strands.

- Insert the wires into the terminals as shown above. Solder the wires to the crimp terminals, using enough solder to completely surround the wire and fill the interior of the terminal. (This may take as long as 10 seconds if you're using a small iron.) Be careful not to get solder on the tongue that extends from the front of the terminal.

Insert the terminals into the housings exactly as shown in Figure 46. The terminals should snap securely in place. Pull on the wires individually and make sure they cannot be pulled out (if so, the terminals are probably inserted upside down).

Optional step: The supplied spring pin may be inserted as shown in the figure above to keep the red and black housing from slipping apart. The manufacturer of the connectors recommends securing the pin with a drop of super-glue.

Prepare the opposite end of the 2-conductor stranded wire and attach the red wire to your power supply positive (+) terminal and the black wire to the power supply negative (-) terminal.

Locate the top cover and the four 3/16" (4.8 mm) screws provided to attach it to the 2D connectors on the top of the transverter.

Clean any paint from the areas where the inside surface of the top cover will contact the 2D connectors when it is installed.

Test fit the top cover in place. Bend resettable fuse F1 in the upper right quadrant toward connector J6 as needed to ensure it clears the top cover. You can leave the top cover off until test and alignment is finished. Set aside four 3/16" (4.8 mm) screws with the cover.

Locate and set aside the nine, 2-pin header shorting blocks. They will be used during alignment and installation to configure your transverter to work with your station equipment.



Skip the next step if you have installed the optional feet and bail assembly.

Attach the self-stick rubber feet to the bottom of your transverter. There are six pre-drilled holes for the optional bail and feet assembly. Use them as a guide for the feet as follows:

- There are two screw holes near the rear edge. Place the rear feet so they are attached only to the bottom cover but where they just cover these holes. One of the feet is a close fit between the edge of the rear cover and the cooling holes.
- There are two screw holes for each attachment for the bail assembly near the front of the bottom cover. Position each front foot so it covers the holes but where it is attached only to the bottom cover.

Locate the male RCA plug. Solder a jumper between the center pin and the shield. This plug will be used during the Alignment procedures.

This completes the assembly of your transverter. You should have a 3-foot length of multiwire cable still in the kit. It is provided to make up the control cable as described in your Owner's Manual.

Go to *Test and Alignment* in on the next page to finish your transverter.

Test and Alignment

In the following steps you will connect your transverter to your station equipment to perform a complete alignment and test procedure. We recommend that you first set up your transverter as described below to complete the initial tests and alignment. Once you have the transverter aligned and tested, your Owner's Manual describes a number of ways you can then alter the installation to best integrate the transverter with your station.

If you encounter any difficulties with the alignment and test procedures:

- _ Carefully check your setup to ensure all cables are properly connected.
- _ Inspect again your parts placement and soldering on the PCBs. Most initial difficulties are eventually traced to an incorrectly placed component or a bad solder connection. The circuit description and schematic diagrams in your Owner's Manual can help you decide which circuits to check, based on where in the alignment and test procedures you experience difficulty.
- _ Refer to the Troubleshooting information in your Owner's Manual for nominal voltages at key points around the circuit in normal operation.

Turn to the Installation Procedures in your Transverter Owner's Manual and follow those instructions to connect your transverter to your other station equipment including the rig you will use for a 28 MHz I.F.

Perform the complete Alignment and Test Procedures in your Owner's Manual to properly adjust and calibrate your transverter and verify that it is operating normally.

Congratulations!

You have completed the assembly, test and alignment of your transverter. Turn to your Owner's Manual for complete installation and operating instructions.

Your Owner's Manual also describes modifications and optional accessories for your transverter that you may choose to best integrate it with your station equipment.